

MEMBER
ABYC
Setting Standards for Safer Boating

5.2

FIVE POINT TWO
ISO 9001

BAYSTAR™

CAPILANO™

SEASTAR™

INSTALLATION INSTRUCTIONS

AND OWNER'S MANUAL

www.seastarsolutions.com

Now with
positionable O-ring
hose fittings



SEASTAR™

BAYSTAR™

SEASTAR™ PRO **BAYSTAR™ PLUS**

Sport & Sport Plus Hydraulic Tilt Helm Pumps



*Before you do it your way,
please try it our way*

Notice to Boat Manufacturer or Installer

Throughout this publication, Warnings and Cautions (accompanied by the International Hazard Symbol ⚠) are used to alert the manufacturer or installer to special instructions concerning a particular service or operation that may be hazardous if performed incorrectly or carelessly.

Observe Them Carefully!

These “safety alerts” alone, cannot eliminate the hazards that they signal. Strict compliance to these special instructions when performing the installation and maintenance plus “common sense” operation are major accident prevention measures.

⚠ DANGER	⚠ WARNING	⚠ CAUTION	NOTICE
Immediate hazards which WILL result in severe personal injury or death.	Hazards or unsafe practices which COULD result in severe personal injury or death.	Hazards or unsafe practices which COULD result in minor injury or product or property damage.	Information which is important to proper installation or maintenance, but is not hazard-related.

⚠ WARNING

Cleaning fluids containing ammonia, acids or any other corrosive ingredients **MUST NOT** be used for cleaning any part of this Hydraulic Steering System. Failure to comply will cause serious damage to the steering system, resulting in possible loss of steering, causing property damage, personal injury and/or death.

NOTICE

Marine Canada Acquisition Inc. DBA SEASTAR SOLUTIONS is referred to as SeaStar Solutions throughout this publication.

⚠ WARNING

DO NOT use BayStar on vessels that exceed a **MAXIMUM** horsepower rating of **150HP (total)**, or on smaller HP outboard engines that use a wing nut type transom mount clamping screws.

⚠ WARNING

BayStar is **NOT** recommended in applications with high steering effort (i.e. such as those using high performance engines or boats capable of attaining high speeds), customers should consider upgrading the system to SeaStar/SeaStar Pro steering. This will reduce the steering effort due to the fact that SeaStar steering provides more output power resulting in lower steering effort. Applications such as these should use SeaStar/SeaStar PRO steering systems **ONLY**.

SAFETY INFORMATION

⚠ WARNING

The safety information provided below is intended to inform you of the dangers that may be present before, during and after the installation. It is critical that you read and understand ALL the points noted.

The safe operation of the steering system is dependant upon proper installation and maintenance, common sense, safe judgment and the knowledge/expertise of the operator. Every installer/user of the steering system should know the following requirements 'before' installing/using the steering system.

If you have any questions regarding any of these warnings, contact SeaStar Solutions.

To reduce risk of severe injury or death. Always wear a Coast Guard Approved personal flotation device (PFD) and use an engine shut-off cord (lanyard).

Before installation

1. Read and understand the Installation and Owner's Manuals provided with your steering components.
2. Ensure that all components required to complete the installation are on hand (including hoses, fittings, oil and the proper tools required for the installation).
3. SeaStar components are highly engineered and safety tested to ensure system integrity, DO NOT substitute any component with non-SeaStar components as this may compromise system performance/reliability.

Installation

⚠ CAUTION

-3 helm pumps are fitted with positionable O-ring style hose fitting ports (referred throughout this manual as ORB). Do NOT attempt to install an NPT pipe fitting into a -3 helm hose fitting port. Doing so will lead to irreparable damage to the helm. ONLY use SeaStar Solutions O-ring style hose fittings (ORB).

1. Install components as directed in all Installation Manuals (including helm pumps, hoses and fitting kits).
2. DO NOT modify or substitute any component in any way without written consent from SeaStar Solutions.
3. Comply with all system ratings/regulations (boat/engine, U.S.C.G.).
 - Cylinder MUST be compatible with engine(s)/rudder(s) and/or outdrive(s) installed.
 - Cylinder MUST be rated for use on the engine(s) installed (outboard applications).
4. Confirm that there is no interference between the steering cylinder(s), tiebars and the transom, splashwell, outboard engine or jackplate or any combination of these parts by performing the following steps;
 - a) With engine fully tilted DOWN, turn steering wheel from hard over to hard over and confirm that no interference occurs.
 - if using a hydraulic jack plate the above must also be performed at all the positions of the jack plate.
 - b) Repeat step 4a) with engines tilted UP.
 - c) Perform step 4a) with each engine in DOWN/UP positions confirming that independent TRIM/TILT can be done without any interference.
5. Confirm that the steering cylinder can be fully stroked in both directions as well as full tilt and trim without stretching, chafing, rubbing and/or kinking of the hydraulic hoses.
6. Confirm that extruded nylon tubing has NOT been substituted for SeaStar Steering Hose. Outboard applications only.
7. DO NOT use a wire coil type trim switch with a hydraulic steering system as the wire can wind up tight around the steering wheel shaft and prevent further steering.
8. Conduct Oil Level and System Check as outlined in your steering cylinder manual.

Safety Information Continued

⚠ WARNING

The safety information provided below is intended to inform you of the dangers that may be present before, during and after use. It is critical that you read and understand **ALL** the points noted.

Prior to every use

1. Check Fluid level in highest helm pump (refer to your steering cylinder manual for proper fluid level setting).
2. Verify immediate steering response when turning steering wheel(s). (Ensure engine turns when steering wheel is turned.)
3. Visually inspect all steering hoses and fittings for wear, kinking and/or leaks.
4. Check for binding, loose, worn or leaking steering components.

DO NOT OPERATE BOAT IF ANY COMPONENT IS NOT IN PROPER WORKING CONDITION.

During use

1. WEAR A COAST GUARD-APPROVED PERSONAL FLOTATION DEVICE (PFD).
2. ATTACH ENGINE SHUT-OFF CORD (LANYARD) TO YOUR PDF.
3. Never allow anyone not familiar with the operation of the steering system operate the boat at any time.
4. Know and adhere to the operator restrictions for your area including;
 - Federal Laws/Regulations,
 - State Laws/Regulations and
 - Municipal Laws/Regulations.

DO NOT OPERATE BOAT IF ANY COMPONENT IS NOT IN PROPER WORKING CONDITION.

After use

1. Rinse off steering system thoroughly using 'fresh, clean water only'.
 - Cleaning fluids containing ammonia, acids or any other corrosive ingredients **MUST NOT** be used for cleaning any part of the hydraulic steering system.

Maintenance

1. Maintain steering system at a minimum of twice per year.
 - See Maintenance section in your steering cylinder manual.

Keep our waters clean for all current and future users. Dispose of ALL fluids in accordance with your local regulations.

INTRODUCTION

The SeaStar/BayStar Steering System is the smoothest and most efficient hydraulic steering system available today. They have been designed for normal pleasure and commercial use where standard rigging arrangements are used. Before proceeding with the installation of this tilt helm, read these instructions thoroughly. SeaStar Solutions cannot accept responsibility for installations where instructions have not been followed, where substitute parts have been used, or where modifications have been made to our products.

This Installation and Owner's Manual covers ALL SeaStar and BayStar, Sport and Sport Plus Tilt helms. Any differences between the helms will be noted where required.

NOTICE

Due to a small amount of internal oil slip, a “master spoke” or “centered” steering wheel (such as those used in automobiles) will not maintain a straight ahead wheel setting. For best results, use an “equal distance spoke” steering wheel.

NOTICE

Help protect your boating environment by ensuring that all used oil is disposed of properly.

Index

Safety Information.....	i
Introduction	1
System Installation Overview	2
Tilt Helm Template	3
Mounting/Installation	5
Sport Tilt Helm	5
Sport Plus Tilt Helm	7
Remote Fill & Vent Kit Installation	9
Postionable ORB Hose Fitting Installation	10
Replacement Parts	11
Maintenance.....	13
Troubleshooting Guide	15
Technical Information	17
Statement of Limited Warranty	18
Return Goods Procedure.....	18

To assist in future troubleshooting, note your helm pump part number here:

HH_____.

SYSTEM INSTALLATION OVERVIEW

STEP 1 STEERING CYLINDER INSTALLATION:

Install your steering cylinder as per the Installation manual provided with your cylinder.



STEP 2 TILT HELM INSTALLATION:

Install your Tilt Helm as per the detailed installation instructions on page 5 to page 8 of this manual.

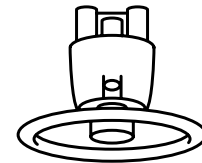

STEP 3 REMOTE FILL & VENT/ORB HOSE FITTING INSTALLATION:

Using page 9 and page 10 in this manual, install the helm fill and vent kit as well as your ORB helm hose fittings.

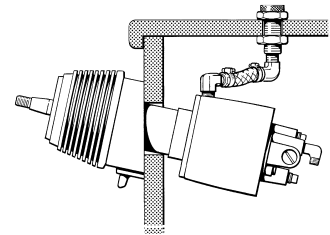

⚠ CAUTION

-3 helm pumps are fitted with positionable O-ring style hose fitting ports (referred throughout this manual as ORB). Do NOT attempt to install an NPT pipe fitting into a -3 helm hose fitting port. Doing so will lead to irreparable damage to the helm. ONLY use SeaStar Solutions O-ring style hose fittings (ORB).

Step 4 FILLING AND PURGING OF STEERING SYSTEM:

Using the Fill and Purge instructions provided in your steering cylinder manual, fill and purge the steering system.

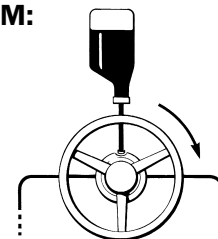

Step 5 OIL LEVEL AND SYSTEM CHECK:

Using the "Oil level and system checks" provided in your steering cylinder manual, confirm proper operation of your steering system.

⚠ WARNING

Oil Level and System Check is critical to the safe operation of your boat, failure to follow this important step may lead to loss of steering control resulting in property damage, personal injury and/or death.

TILT HELM TEMPLATE

Tilt Helm Mounting Template

NOTICE

If you must photocopy this mounting template for use, check ALL measurements using a measuring device prior to using as a template.

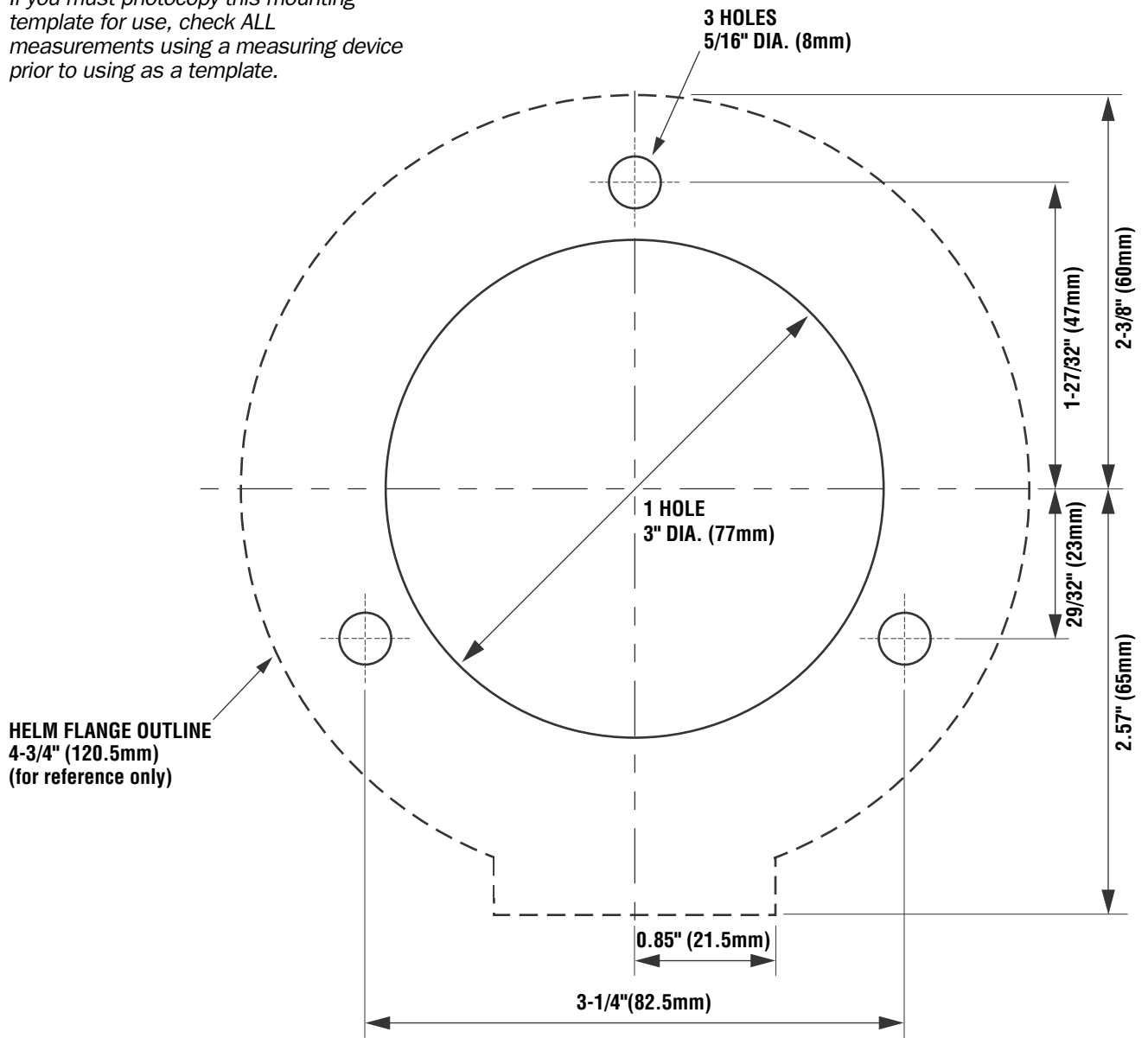

Note: *This page left blank intentionally.*

MOUNTING/INSTALLATION

Sport Tilt Helm

⚠ WARNING

Use the self-locking fasteners provided **ONLY**; substituting non-self locking fasteners can result in loosening or separation of equipment leading to loss of steering control causing property damage and/or personal injury.

For Replacement Parts refer to page 11.

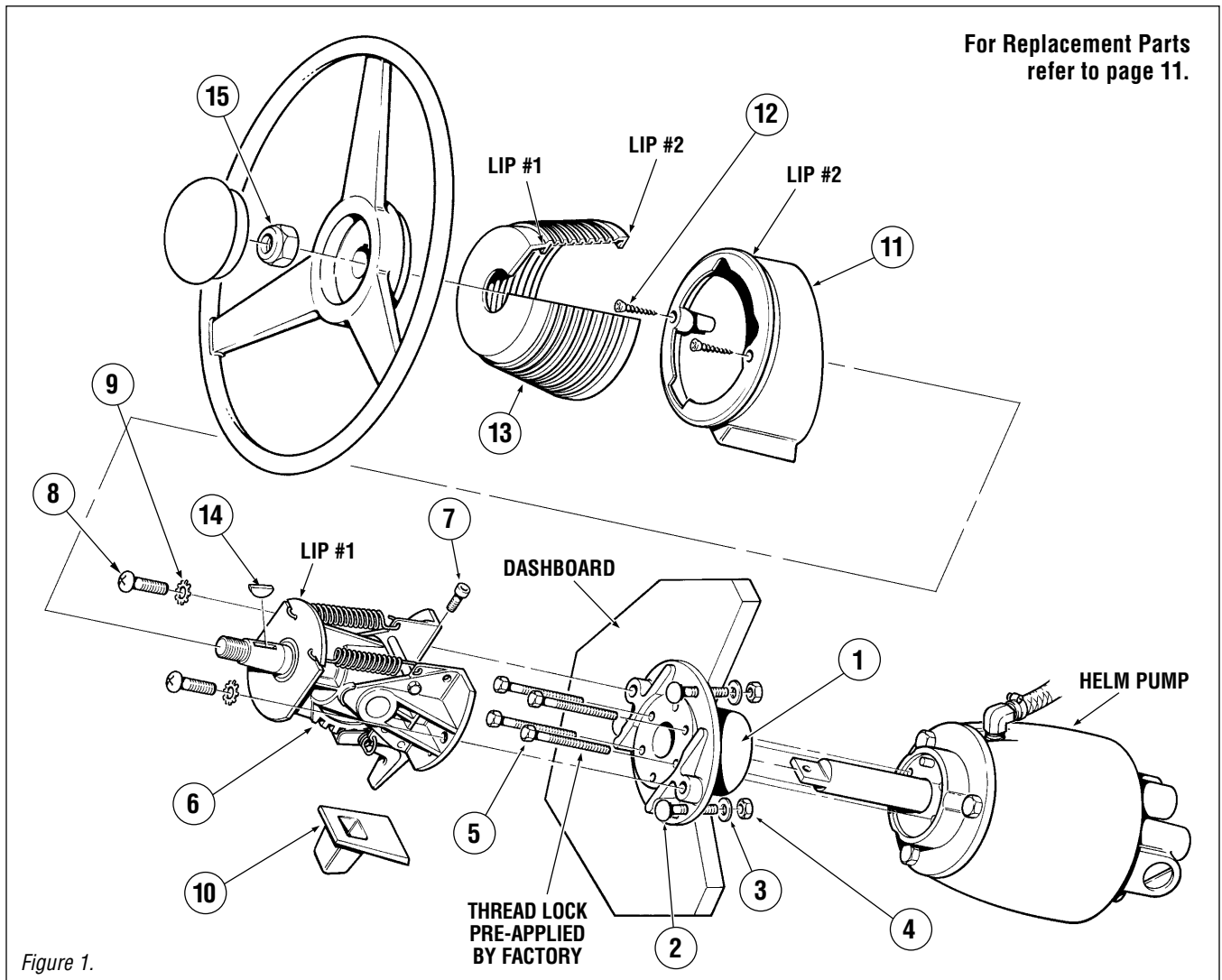

Figure 1.

ITEM	PART #	QTY	DESCRIPTION
1	279068	1	Tilt Plate
2	954829	3	CB 1/4" NC x 2"
3	201429	3	Washer, 1/4" Flat SS
4	067424	3	Nut, 1/4" NC, Nyloc®
5	007279	4	HHCS 1/4" NC x 2-1/2" SS
6	182220	1	Tilt Mechanism
7	757927	1	SCHS #10-24 x 7/8" SS
8	958627	2	PHMS 5/16" NC x 3/4"

ITEM	PART #	QTY	DESCRIPTION
9	957725	2	Washer, Star
10	157616	1	Boot Latch
11	183818	1	Bezel, Lower
12	952623	2	#8-32 x 1"
13	279047	1	Bellows
14	260130	1	Shaft Key
15	747521	1	Wheel Shaft Nut

⚠ WARNING

Use self-locking fasteners provided ONLY; substituting non-self locking fasteners can result in loosening or separation of equipment leading to loss of steering control causing property damage and/or personal injury. DO NOT exceed 110 in-lb. (12Nm) torque on helm nuts and bolts.

NOTICE

If the helm pump shaft is difficult to locate into the tilt mechanism coupling, loosen the TOP screw in the coupling by NO MORE than 1/4 of a turn. Ensure that this screw is fully tightened before installing the bezel.

STEP 1. Using the template provide on page 3. Confirm that the location of the Tilt Helm will allow unrestricted operation of the steering wheel in **ALL** tilting positions and will **NOT** interfere with other functional equipment.

STEP 2. Tape the template to the dash and use a center punch for locating the holes on the dash. Double check to ensure unrestricted operation of the steering wheel in **ALL** tilting positions.

STEP 3. Drill the required diameter center hole and the specified number and size of mounting bolts as shown in the template.

STEP 4. Mount Tilt Plate (Item 1) to the dash using the three 1/4" NC x 2" carriage bolts (Item 2), washers (Item 3) and self locking nuts (Item 4)

STEP 5. Mount the helm pump from behind the dash to the tilt mounting plate (Item 1) so that the four helm mounting holes align with the applicable holes in the tilt mounting plate. Apply a small amount of the supplied Loctite® on ALL four of the 1/4 x 2-1/2" hex head bolts (Item 5) and secure them to the helm pump.

STEP 6. Attach the helm shaft to the tilt mechanism (Item 6) by lining up the coupling slot with the helm shaft tongue and secure with the no. 10 - 24 x 7/8" (Item 7).

STEP 7. Tighten the two PHMS 5/16" NC x 3/4" screws (Item 8), and star washers (Item 9) to secure the tilt mechanism to the dash plate.

STEP 8. Install boot latch (Item 10) onto the tilt latch of tilt mechanism.

STEP 9. Position the tilt unit in the middle position and mount the lower bezel (Item 11) to the tilt mechanism ensuring that the boot latch (Item 10) is held into the slots provided in the lower bezel (Item 11). Secure the bezel with the two PHMS #8-32 x 1" (Item 12).

STEP 10. Install boot cover (Item 13) over lip 1 of the tilt mechanism and around lip 2 of the lower bezel (shown in Figure 1).

STEP 11. Grease steering shaft with a good quality marine grease.

STEP 12. Install woodruff key (Item 14) and wheel shaft nut (Item 15). Tighten wheel shaft nut prior to continuing on with instructions. Torque wheel shaft nut to 150 in-lb, **DO NOT** exceed 200 in-lb.

STEP 13. Confirm proper function of the tilt mechanism:

- Push the tilt latch forward to unlock the tilt mechanism
- Check ALL positions of the tilt and confirm that the latch locks in place for each position, tilt lever will click back into the locked position.

STEP 14. ONLY if the tilting function is confirmed to function, continue to page 9 for remote fill kit installation and page 10 ORB hose fitting Installation.

Sport Plus Tilt Helm

⚠ WARNING

Use the self-locking fasteners provided **ONLY**; substituting non-self locking fasteners can result in loosening or separation of equipment leading to loss of steering control causing property damage and/or personal injury.

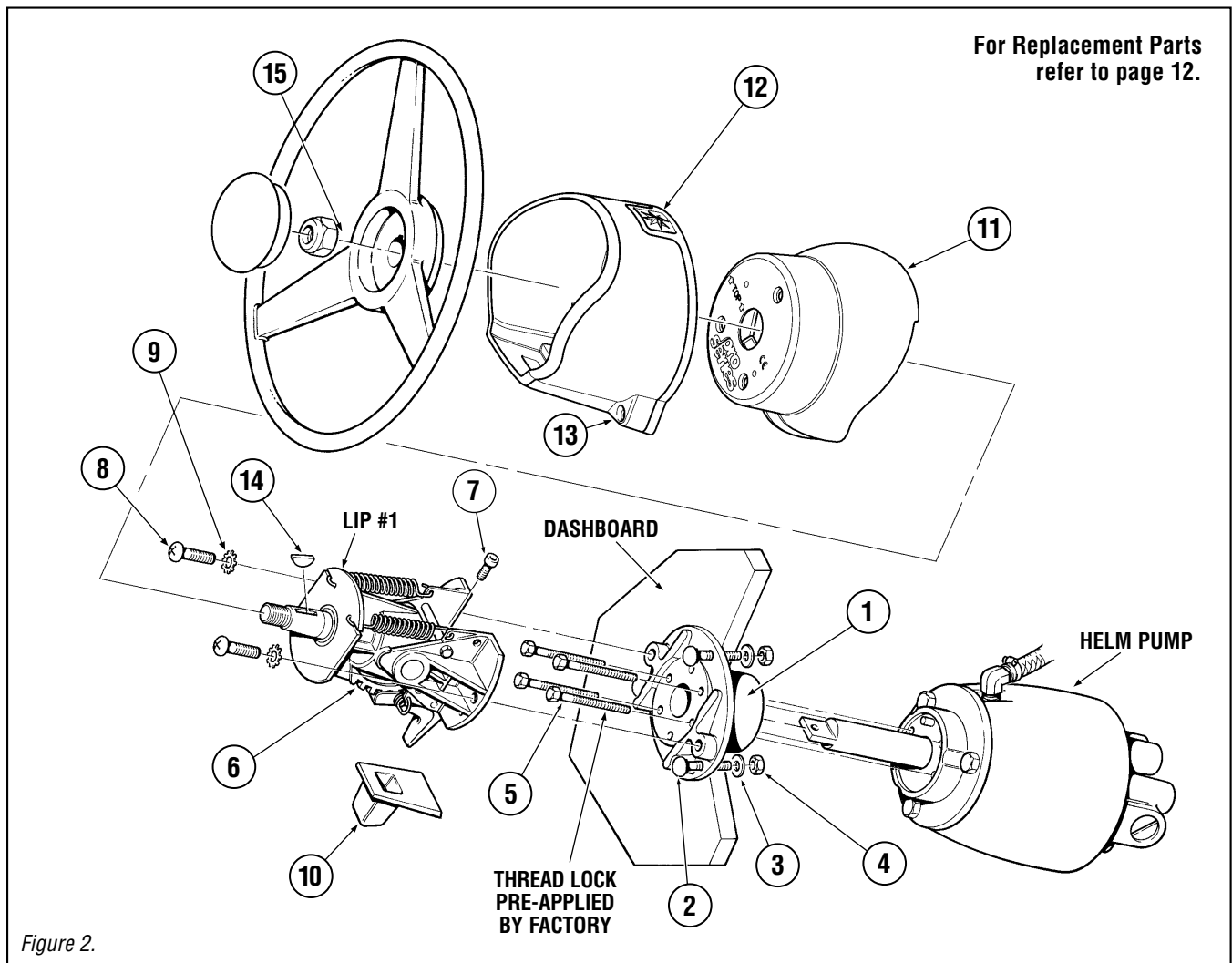

ITEM	PART #	QTY	DESCRIPTION
1	279064	1	Tilt Plate
2	984829	3	CB 1/4" NC x 2"
3	201429	3	Washer 1/4" Flat SS
4	067424	3	Nut, 1/4" NC, Nyloc®
5	007279	4	HHCS 1/4" NC x 2-1/2" SS
6	182220	1	Tilt Mechanism
7	757927	1	SCHS #10-24 x 7/8" SS
8	958627	2	PHMS 5/16" NC x 3/4"

ITEM	PART #	QTY	DESCRIPTION
9	957725	2	Washer, Star
10	279049	1	Latch Boot
11	279041	1	Upper Bezel
12	279045	1	Lower Bezel
13	279082	5	BHSCS 8-32 x 1/2" SS
14	260130	1	Shaft Key
15	747521	1	Wheel Shaft Nut

NOTICE

*If the helm pump shaft is difficult to locate into the tilt mechanism coupling, loosen the TOP screw in the coupling by **NO MORE** than 1/4 of a turn. Ensure that this screw is fully tightened before installing the bezels.*

NOTICE

Ensure that tilt latch boot (Item 10) is properly fitted into the slots provided in the lower bezel.

STEP 1 Using the template provided on page 3. Confirm that the location of the helm will allow unrestricted operation of the steering wheel in **ALL** tilting positions and will **NOT** interfere with any other functional equipment.

STEP 2 Tape the template to the dash and use a center punch for locating the holes on the dash. Double check to ensure unrestricted operation of the steering wheel in **ALL** tilting positions.

STEP 3 Drill required diameter center hole and the specified number and size of the mounting bolts as shown in the template.

STEP 4 Mount Tilt plate (Item 1) to the dash using the three 1/4" NC x 2" carriage bolts (Item 2, washers (Item 3) and self locking nuts (item 4). Torque to 110 in/lb.

STEP 5 Attach the helm shaft to the tilt mechanism (Item 6) by lining up the coupling slot with the helm shaft tongue and secure with the one 10-24 NC x 7/8" bolt (Item 7). Torque to 20-24 in/lb.

STEP 6 Install and tighten the two PHMS 5/16" NC x 3/4" screws (Item 8) and the star washers (Item 9) to secure the tilt mechanism to the dash plate. Torque to 160-180 in/lb.

STEP 7 Install the boot latch (Item 10) onto the tilt latch of the tilt mechanism.

STEP 8 Fit the upper bezel (Item 11) into the lower bezel (Item 12) and position two parts over the tilt mechanism. Install the 5 x BHSCS 8-32 x 1/2" SS (Item 13) screws into the position show.

STEP 9 Grease steering shaft with good quality marine grade grease.

STEP 10 Install the woodruff key (Item 14) and wheel shaft nut (Item 15), Tighten steering wheel shaft nut prior to continuing with installation instructions. Torque wheel shaft nut to 150 in/lb.

DO NOT exceed 200 in/lb.

STEP 11 Confirm proper function of the tilt mechanism using the following points.

Push tilt latch forward to 'unlock' the tilt mechanism.

Check **ALL** positions of the tilt and confirm that the latch 'locks' in place for each position, tilt lever will click back into the locked position.

STEP 12 ONLY if the tilting function is confirmed to function, continue to page 9 for remote fill kit installation and page 10 ORB hose fitting Installation.

Remote Fill & Vent Kit Installation

Remote Fill & Vent

NPT fitting installations ONLY:

- Apply a liquid, Teflon based pipe sealant onto the threads going into the pump
- Tighten fitting **HAND-TIGHT**
- using a wrench, tighten an additional 1.5 turns
- continue to tighten until desired orientation is met

⚠ CAUTION

DO NOT attempt to install NPT pipe fittings into a cylinder and/or helm pump fitted with ORB hose fitting port. Doing so will lead to irreparable damage to the cylinder and/or helm port. ONLY use SeaStar ORB hose fittings provided by SeaStar Solutions.

DO NOT use steel NPT fittings with SeaStar Helm Pumps, use brass NPT fittings ONLY.

This kit will provide means to fill and vent the steering system above the dash or console. A 7/8" hole will need to be drilled into the dash/console **ABOVE** the helm pump, prior to drilling any holes, confirm that you will not drill into any functioning equipment.

1. Locate desired location for placement of the helm fill plug onto of the dash/console. Look beneath the dash/console to confirm that there is sufficient space for the fill hose and fittings. Confirm that there is no interference with any other equipment. Mark the location and drill a 7/8" hole from above or below the dash/console.
2. Apply a liquid, Teflon based pipe sealant to the threads of the elbow fitting going into the helm pump, **DO NOT** use Teflon Tape, **ONLY** use the paste type pipe sealant. Screw the brass elbow barb fitting into the helm fill port. **DO NOT** install the plastic elbow fitting into the helm.

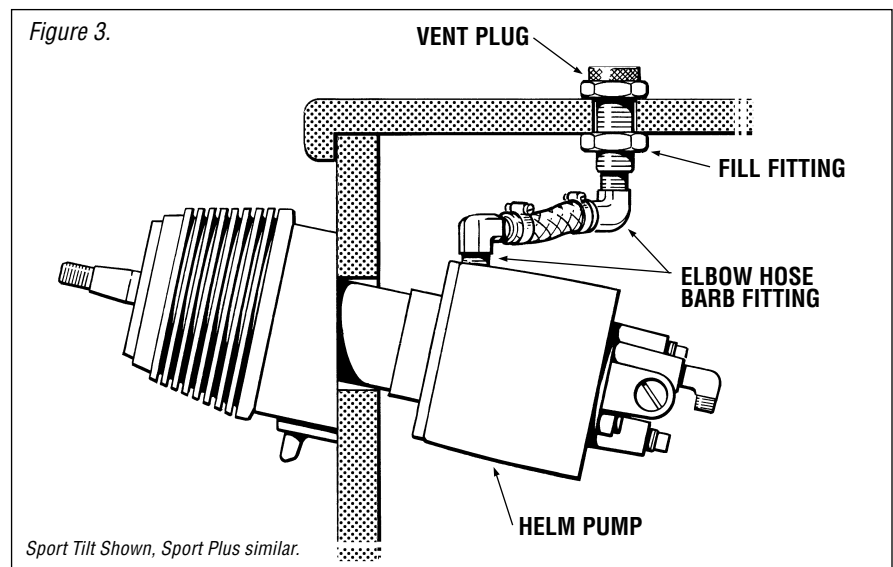

3. Attach the vinyl tubing to the elbow fitting that you just installed into the helm pump and secure with a hose clamp. A small amount of oil inside the vinyl tube will help slide it onto the elbow barb fitting.
4. Insert fill fitting from the top of the dash/console and secure with the jam nut.

NOTICE

A spacer may be required if mounting surface is less than 3/8" thick, this spacer is provided in this kit

5. Apply a liquid, Teflon based pipe sealant to the threads of the plastic elbow fitting that will be installed into the fill fitting. **DO NOT** use Teflon Tape; **ONLY** use the paste type pipe sealant.
6. Vinyl hose **MUST** have a gradual rise from the helm fitting to the fill fitting to allow air to rise. Cut vinyl tube to the required length and secure to the fill fitting with a hose clamp.

TIP: Measure twice; cut once.

Re-Positionable O-Ring Helm Pump Fittings Installation/Realignment

⚠ CAUTION

-3 helm pumps are fitted with positionable O-ring style hose fitting ports (referred throughout this manual as ORB). Do NOT attempt to install an NPT pipe fitting into a -3 helm hose fitting port. Doing so will lead to irreparable damage to the helm. ONLY use SeaStar Solutions O-ring style hose fittings (ORB).

Re-Positionable Pump Fitting Installation

⚠ WARNING

Failure to properly tighten the lock-nut (item 1) may lead to loss of steering control. Loss of steering control may result in unpredictable boat behavior, collision with an obstacle and/or ejection from vessel, leading to property damage, personal injury and/or death.

NOTE: for straight ORB fittings simply torque fitting to 18 ft-lbs. Fitting re-orientation not required.

1. Back off lock nut (item 1), counter-clockwise, until it stops.

NOTE: O-ring must be fully on sealing surface and cannot contact any threads. Do not use Teflon tape or any liquid pipe sealant with ORB fittings.

2. Thread fitting into helm port until fitting washer (item 2) contacts the face of the helm port. Tighten hand tight. **DO NOT USE A WRENCH.**
3. Re-position fitting to desired orientation by turning it counter-clockwise to a MAXIMUM of 1 full turn.
4. While holding the fitting body securely with a wrench, torque the lock nut (item 1) to **18 ft-lbs.**
5. While holding the fitting body securely with a wrench, torque the hose end nut to **15 ft-lbs.**
6. Purge system per applicable instruction manual.

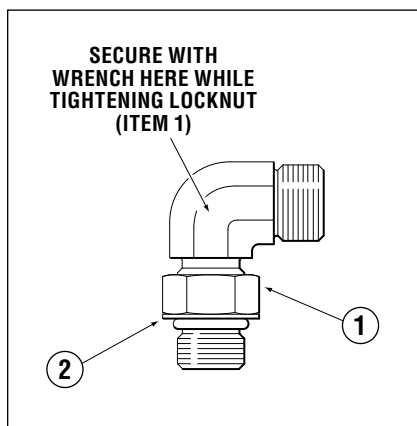

Figure 4.

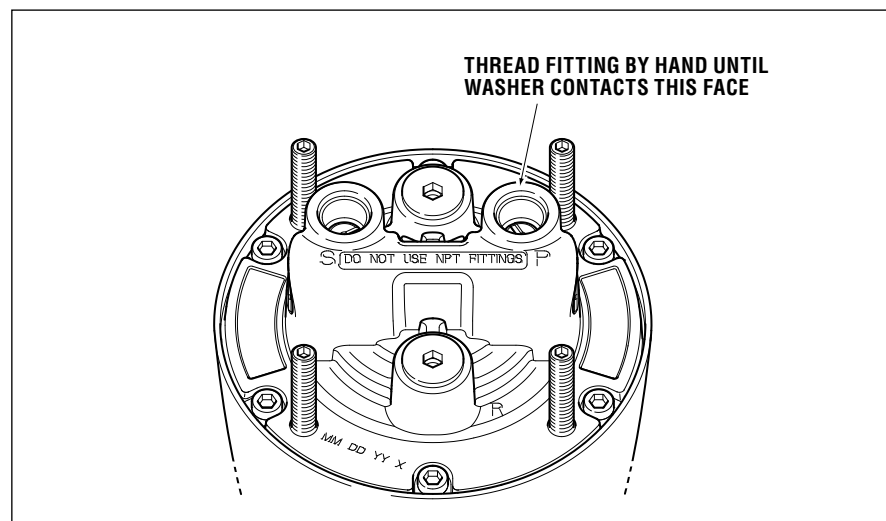

Figure 5.

⚠ WARNING

SeaStar Solutions recommends that the hose and hose fittings are checked on a regular basis to ensure the safe operation of the steering system.

REPLACEMENT PARTS

Sport Tilt Helms

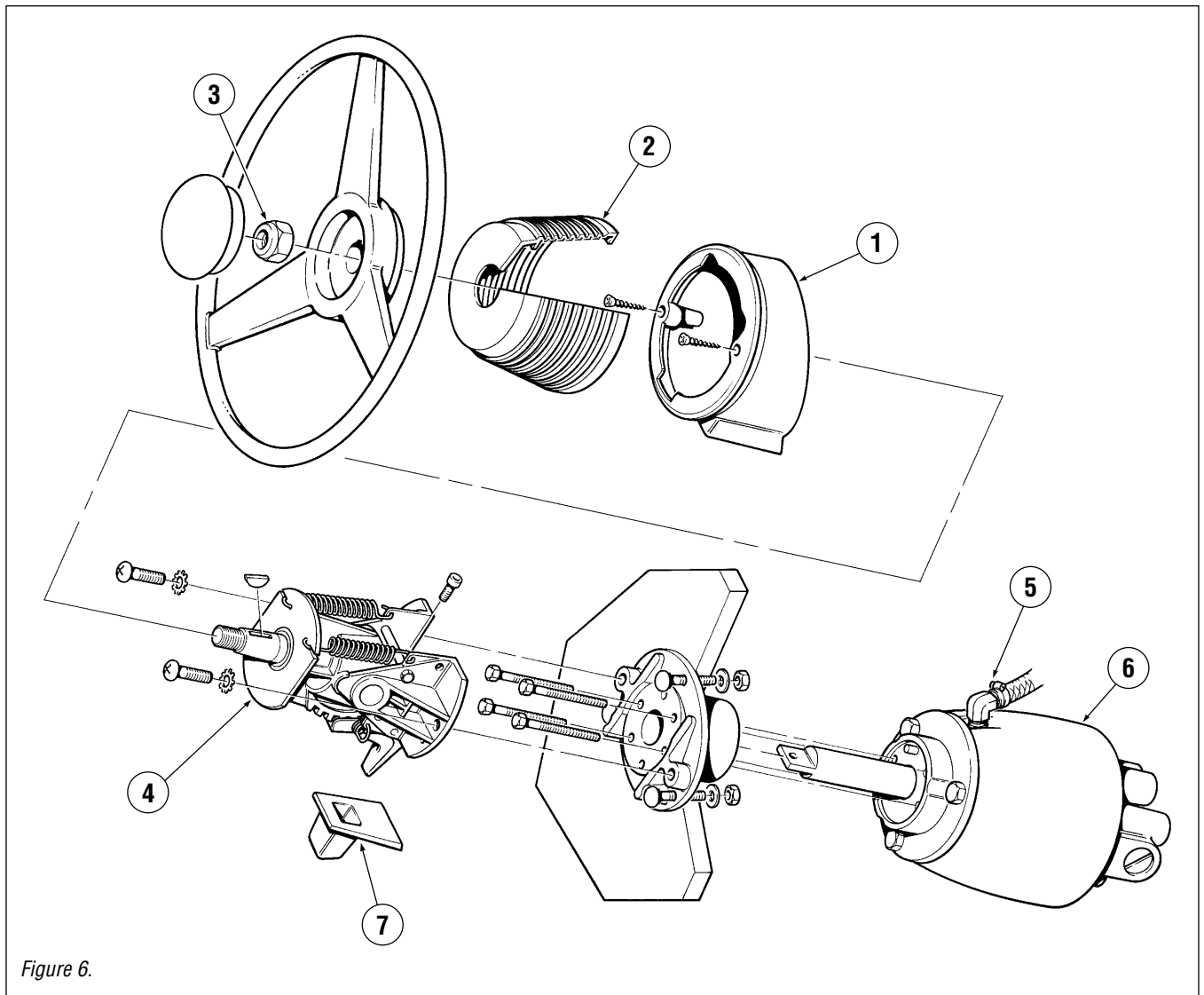

Figure 6.

ITEM	KIT #	QTY (In Kit)	DESCRIPTION	NOTES
1	HP6053	1	Lower Bezel	
2	HP6046	6	Bellows	
3	HP6032	1	Wheel Shaft Nut	<i>Inc. Shaft Seal, Wheel Shaft Key and Vent Cap</i>
4	HA6123	1	Tilt Mechanism Replacement	<i>Ships with Items 1, 2, 4 & 7</i>
5	HA6450	1	Remote Filler Kit	
6	N/A	N/A	Helm Pump	<i>Helm Not Sold Separately</i>
7	N/A	N/A	Boot Latch	<i>Contact Tech. Support</i>

Replacement Parts Continued

Sport Plus Helms

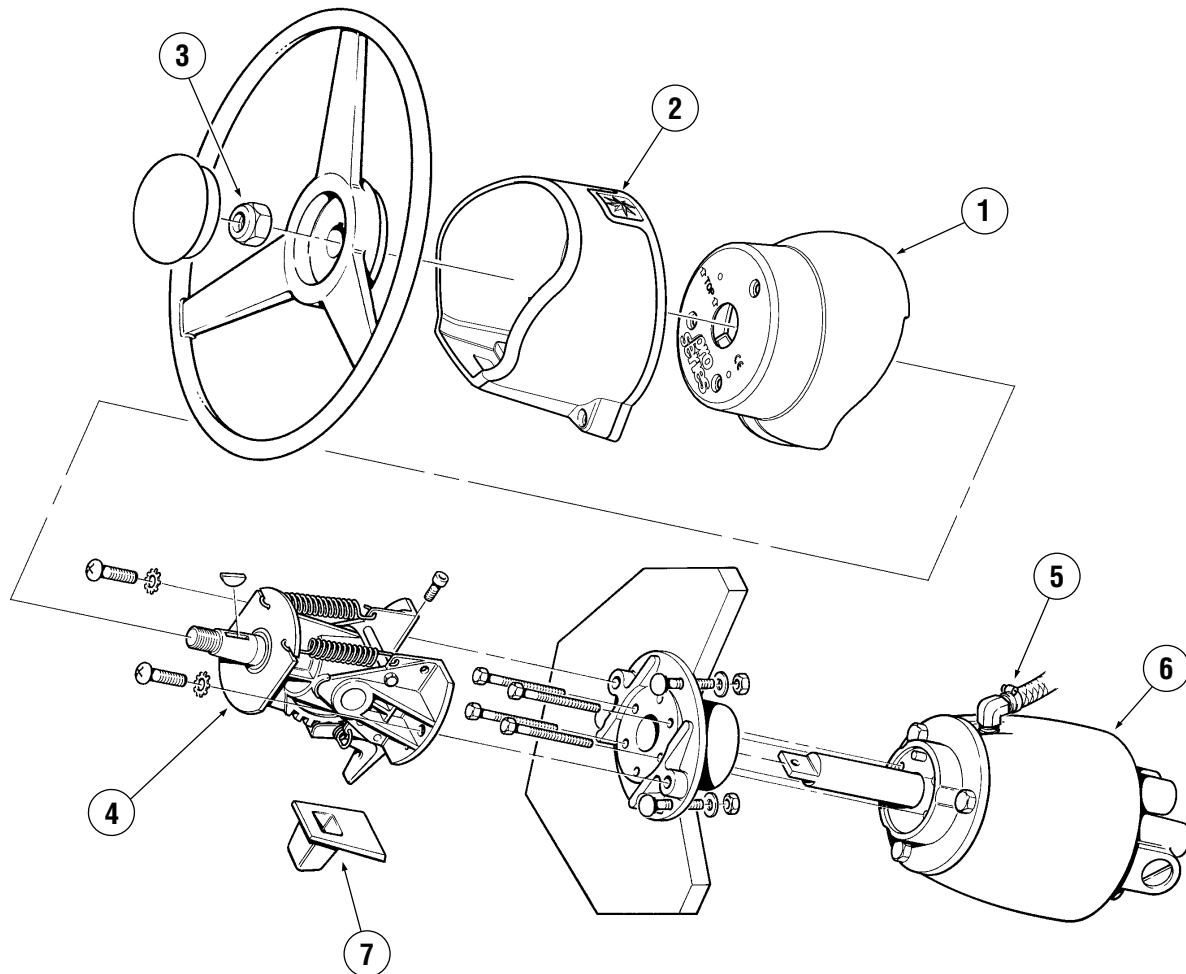

Figure 7.

ITEM	KIT #	QTY (In Kit)	DESCRIPTION	NOTES
1	N/A	N/A	Upper Bezel	<i>Ships with HA6423 (item 4)</i>
2	N/A	N/A	Lower Bezel	<i>Ships with HA6423 (item 4)</i>
3	HP6032	1	Wheel Shaft Nut	<i>Inc. Shaft Seal, Wheel Shaft Key and Vent Cap</i>
4	HA6423	1	Tilt Mechanism Replacement	<i>Ships with Items 1, 2, 4 & 7</i>
5	HA6450	1	Remote Filler Kit	
6	N/A	N/A	Helm Pump	<i>Helm Not Sold Separately</i>
7	N/A	N/A	Boot Latch	<i>Ships with HA6423 (item 4)</i>

MAINTENANCE

Following the routine maintenance schedules noted below, in the time frame noted will ensure years of great service of your SeaStar Steering System, as well as keep you and your passengers safe from the dangers that are present on the water. Always refer to ALL installation manuals provided with your helm, cylinders and any other part of your steering system for a complete list of routine maintenance procedures. If you are instructed to consult with ANY manual that you may not have, please contact SeaStar Solutions for the proper manual.

Every trip, prior to engine start up and/or launch

- Check fluid level in helm pump (consult your steering cylinder installation manual for proper oil level setting)
- Hoses – Ensure hoses are in good condition and free of wear, kinks or any other signs of damage. If hose/tube shows signs of wear, they **MUST** be replaced prior to operation.
- Turn steering wheel(s) hard over to hard over to ensure engine(s), rudder(s) and/or outdrive(s) are responding to input from the wheel. If vessel is fitted with multiple steering stations, check ALL wheels and autopilot if equipped.

Every 100 hours or 3 months (whichever comes first)

- All points noted in Step #1.
- Check torque setting on ALL fasteners throughout the steering system. Refer to page 10 for torque specifications and tighten as required.

Every 6 months

- ALL points noted in Steps #1 and #2.
- Remove steering wheel from helm pump. Clean wheel shaft and apply a good quality marine grease. Reinstall steering wheel and wheel shaft nut, torque to 150 in/lbs.

NOTICE

Ensure wheel shaft nut is torque as per torque setting on page 6.

⚠ WARNING

Failure to comply with the maintenance checks as noted above may result in loss of steering control and unpredictable boat behavior, which may result in person(s) being ejected from the boat or collision with obstacle(s) causing property damage, personal injury and/or death.

Note: *This page left blank intentionally.*

TROUBLESHOOTING GUIDE

FAULT	CAUSE	SOLUTION
1. Cannot get helm shaft to go into U-Joint.	<ul style="list-style-type: none"> U-Joint bolt is too tight. 	<ul style="list-style-type: none"> Loosen the "Top" bolt no more than 1/4" to allow the Helm shaft to be installed.
2. Tilt will not lock into place.	<ul style="list-style-type: none"> Spring has come undone. Or a broken Tilt tooth. 	<ul style="list-style-type: none"> Re-attach spring. Replace Tilt mechanism.
3. Fluid is leaking from where the elbow fitting is installed into the Helm pump fill port.	<ul style="list-style-type: none"> No pipe sealant installed onto threads. Hose clamp not tightened down. 	<ul style="list-style-type: none"> Re-apply Teflon[®] based pipe sealant, NO TEFLON[®] TAPE. Tighten hose clamp fully.
4. Wheel is really hard to turn in both directions.	<ul style="list-style-type: none"> Tilt boot is rubbing on the steering wheel hub. 	<ul style="list-style-type: none"> Confirm that the rubber boot is installed over both lips and is NOT rubbing on the wheel hub.
5. Cannot remove steering wheel.	<ul style="list-style-type: none"> Seized in place. No grease applied to shaft before wheel installation. 	<ul style="list-style-type: none"> Using your knee under the wheel and your hand on top, with the wheel shaft nut installed one turn on shaft, lightly tap helm shaft to release wheel.
6. During filling, helm becomes completely jammed.	<ul style="list-style-type: none"> Blockage in the line between the helm(s) and cylinder(s). PRO helm used with an unbalanced cylinder. Tilt mechanism to helm pump wheel shaft nut, NOT installed properly. 	<ul style="list-style-type: none"> Make certain hose/tubing has not collapsed during installation. DO NOT use ANY PRO helm pump with ANY un-balanced cylinder. Tighten and torque nut.
7. System is very difficult to fill. Air keeps burping out top of helm, even after system appears full.	<ul style="list-style-type: none"> System is not being bled properly/completely. Cylinder is mounted upside down, trapping air in cylinder body. 	<ul style="list-style-type: none"> Consult with your cylinder installation manual for proper bleeding. If boat is fitted with an autopilot, ensure the a/p pump is jogged back and fourth for several seconds during the bleeding procedure. Install cylinder with bleed fittings pointing UP. If unable to mount cylinder in this position, you MUST disconnect cylinder, bleed system, then reinstall.

8. Steering is stiff and hard to turn, even when the vessel is not moving.

- Mechanical binding of rudder(s), outboard engine(s), or outdrive(s).
- Restrictions in hose/tube.
- Air in system.
- Wrong fluid has been used.

- Ensure rudder(s), outboard(s) or sterndrive(s) move freely with cylinder disconnected.
- See fault 1.
- See fault 2.
- Only use SeaStar Steering Fluid, or any other fluid that meets MIL-PRF-5606H.

9. One helm unit is very bumpy and requires too many turns hard over to hard over.

- Debris in inlet check of helm pump.

- Contact Authorized repair facility, or, replace helm pump.

10. Steering is easy to turn at the dock, but, becomes hard to turn when underway.

- Steering wheel is too small.
- Cylinder doesn't provide enough force to turn rudder(s).
- Incorrectly set, or adjusted torque tab.
- Mechanical interference.

- Install larger wheel (MAX 28").
- Confirm cylinder installed is that for the boat.
- Re-adjust torque tab.
- See fault 3.

11. Turning one wheel causes the other wheel to turn on its own.

- Debris in inlet checks of helm pump.

- Contact Authorized repair facility, or, replace helm pump.

TECHNICAL INFORMATION

⚠ WARNING

Failure to adhere to the torque specifications below may lead to separation of components resulting in loss of steering control causing ejection from vessel, or collision with obstacles, leading to property damage, personal injury and/or death.

Bolt Torque Specifications

These are the recommended maximum torque values for reusable dry bolts. Bolts should be torqued to this value +0% -20%. For lubricated bolts, multiply the dry bolt torque values by .75.

Values are stated in: **in/lbs (N.m)**

Bolt Size	18-8SS	Brass	Bolt Size	18-8SS	Brass	Bolt Size	18-8SS	Brass
2-56	2.5 (.282)	2.0 (.226)	6-32	9.6 (1.08)	4.9 (.554)	5/16"-18	132.0 (14.91)	107.0 (12.10)
2-64	3.0 (.338)	2.5 (.282)	6-40	12.0 (1.35)	9.9 (1.12)	5/16"-24	142.0 (16.04)	116.0 (13.11)
3-48	3.9 (.440)	3.2 (.361)	8-32	20.0 (2.25)	16.0 (1.81)	3/8"-16	236.0 (26.66)	192.0 (21.71)
3-56	4.4 (.497)	3.6 (.407)	8-36	22.0 (2.48)	18.0 (2.03)	3/8"-24	259.0 (29.20)	212.0 (23.97)
4-40	5.2 (.587)	4.3 (.486)	10-24	23.0 (2.59)	19.0 (2.14)			
4-48	6.6 (.740)	5.4 (.610)	10-32	32.0 (3.61)	26.0 (2.94)			
5-40	7.7 (.869)	6.3 (.712)	1/4"-20	75.0 (8.47)	62.0 (7.01)			
5-44	9.4 (1.06)	7.7 (.869)	1/4"-28	94.0 (10.6)	77.0 (8.70)			

Values are stated in: **ft/lbs (N.m)**

Bolt Size	18-8SS	Brass	Bolt Size	18-8SS	Brass	Bolt Size	18-8SS	Brass
7/16"-14	31.0 (42.00)	26.0 (35.25)	5/8"-11	93.0 (126.09)	76.0 (103.04)	1"-8	287.0 (389.12)	235.0 (318.62)
7/16"-20	33.0 (44.74)	27.0 (36.61)	5/8"-18	104.0 (141.00)	85.0 (115.24)	1"-14	259.0 (351.16)	212.0 (287.43)
1/2"-13	43.0 (58.30)	35.0 (47.45)	3/4"-10	128.0 (173.55)	104.0 (141.00)			
1/2"-20	45.0 (61.01)	37.0 (50.17)	3/4"-16	124.0 (168.12)	102.0 (138.29)			
9/16"-12	57.0 (77.28)	47.0 (63.72)	7/8"-9	194.0 (236.03)	159.0 (215.58)			
9/16"-18	63.0 (85.42)	51.0 (69.15)	7/8"-14	193.0 (261.67)	158.0 (214.22)			

Helm Pump

	VALVE	TILT TYPE	DISPLACEMENT	RELIEF VALVE	PORTS*
HH4315-3	Regular	Sport	1.4 cu. in. (22.9 cc)	1000 PSI (6.9 MPa)	-5 ORB
HH4316-3	Regular	Sport Plus	1.4 cu. in. (22.9 cc)	1000 PSI (6.9 MPa)	-5 ORB
HH4513-3	Regular	Sport	1.4 cu. in. (22.9 cc)	1000 PSI (6.9 MPa)	-5 ORB
HH6145-3	Regular	Sport	2.0 cu. in. (33.0 cc)	1000 PSI (6.9 MPa)	-5 ORB
HH6189-3	Pro	Sport	1.7 cu. in. (27.8 cc)	1500 PSI (10.3 MPa)	-5 ORB
HH6190-3	Pro	Sport	2.0 cu. in. (33.0 cc)	1500 PSI (10.3 MPa)	-5 ORB
HH6191-3	Regular	Sport	1.7 cu. in. (27.8 cc)	1000 PSI (6.9 MPa)	-5 ORB
HH6192-3	Regular	Sport	2.4 cu. in. (39.3 cc)	1000 PSI (6.9 MPa)	-5 ORB
HH6193-3	Regular	Sport	1.4 cu. in. (22.9 cc)	1000 PSI (6.9 MPa)	-5 ORB
HH6345-3	Regular	Sport Plus**	2.0 cu. in. (33.0 cc)	1000 PSI (6.9 MPa)	-5 ORB
HH6445-3	Regular	Sport Plus	2.0 cu. in. (33.0 cc)	1000 PSI (6.9 MPa)	-5 ORB
HH6489-3	Pro	Sport Plus	1.7 cu. in. (27.8 cc)	1500 PSI (10.3 MPa)	-5 ORB
HH6490-3	Pro	Sport Plus	2.0 cu. in. (33.0 cc)	1500 PSI (10.3 MPa)	-5 ORB
HH6491-3	Regular	Sport Plus	1.7 cu. in. (27.8 cc)	1000 PSI (6.9 MPa)	-5 ORB
HH6492-3	Regular	Sport Plus	2.4 cu. in. (39.3 cc)	1000 PSI (6.9 MPa)	-5 ORB
HH6493-3	Regular	Sport Plus	1.4 cu. in. (22.9 cc)	1000 PSI (6.9 MPa)	-5 ORB

* Helm fill/vent port is a 1/4" NPT port.

** Splined Wheel Shaft

Helm Pump Shaft

TAPER	THREAD	KEY SIZE
3/4" Standard, 1" per ft.	5/8" NF	3/16"
** Spline	1/2" NF	N/A

Statement of Limited Warranty

We warrant to the original retail purchaser that **Marine Canada Acquisition Inc. DBA SEASTAR SOLUTIONS** (herein forward referred to as **SeaStar Solutions**) products have been manufactured free from defects in materials and workmanship. This warranty is effective for two years from date of purchase, excepting that where **SeaStar Solutions** products are used commercially or in any rental or income producing activity, then this warranty is limited to one year from the date of purchase.

We will provide replacement product without charge, for any **SeaStar Solutions** product meeting this warranty, which is returned (freight prepaid) within the warranty period to the dealer from whom such product were purchased, or to us at the appropriate address. In such a case **SeaStar Solutions** products found to be defective and covered by this warranty, will be replaced at **SeaStar Solutions'** option, and returned to the customer.

The above quoted statement is an extract from the complete **SeaStar Solutions** products warranty statement. A complete warranty policy is available in our **SeaStar Solutions** products catalogue.

Return Goods Procedure

Prior to returning product to **SEASTAR SOLUTIONS** under warranty, please obtain a *Return Goods Authorization number* (claim number).

Be sure to label the goods with:

- a) the name and address of the sender, and
- b) the return goods authorization number (claim number)

Please address the returned goods as follows:

From U.S.A.

RGA # ?
SeaStar Solutions
c/o UPS-SCS
19308 70th Ave S.
Kent, WA 98032

From Canada

RGA # ?
SeaStar Solutions
3831 No.6 Road
Richmond, B.C.
Canada V6V 1P6

Technical Support

Phone: 604-248-3858

email: seastar@seastarsolutions.com

Hours: Monday to Friday 05:00 – 15:30 PST

Web: www.seastarsolutions.com

© 2014 MARINE CANADA ACQUISITION INC.
DBA SEASTAR SOLUTIONS

PRINTED IN CANADA 02/18

Please scan
this QR code
and watch our
latest **Boating
Safety** video.



SEASTAR SOLUTIONS
3831 NO. 6 ROAD
RICHMOND, B.C.
CANADA V6V 1P6

FAX 604-270-7172

www.seastarsolutions.com

ISO 10592



FORM NO. 998001 REV. G

