

▶ Table of Contents

Warnings...	1-3
Personal Precautions...	4
Overview...	5
Features...	6-8
Setup And Operation...	9-14
Installation...	14-26
Post Installation - Pre-start Checklist...	27
Troubleshooting...	28-29
Appendix 1 Load Calculations...	30-32
Appendix 2 Technical Specifications...	33-34

▶ Introduction

Thank you from all of us at ProMariner. Congratulations on your recent purchase of a TruePower Combi Charger/Inverter!

Important Notice – Please read and understand this manual before installing your TruePower Combi Charger/Inverter.

 This manual is written to assist in the installation of your new TruePower Combi Charger/Inverter; however, since this is a permanent AC and DC hardwired installation, ProMariner strongly recommends that a Certified Marine Electrical Technician® trained by the American Boat & Yacht Council (ABYC) perform the installation. The TruePower Combi unit you have purchased is constructed to the safety standards of the ABYC to prevent fire and electrocution; the installation must conform to these same industry standards. For more information on ABYC, their Standards and Technical Information reports for Small Craft, and to find a certified technician near you, visit www.abycinc.org.

 To Preclude a Safety Hazard, all existing AC and DC electrical components (e.g. wire, fuses, circuit breakers, battery switches, connections) must be inspected for proper condition prior to installation. Failure to confirm adequate condition and proper installation to ABYC Standard E-11 AC & DC Electrical Systems on board boats may result in a dangerous condition and/or premature failure of this or other installed electrical components. Any and all areas of the existing system that are found not in compliance with ABYC E-11 must be replaced prior to installation.

Warnings

Important Notice: FCC Class A Notification & International Standards Compliance

NOTE: This equipment has been tested and found to comply with the limits for a Class A digital device, pursuant to Part 15 of the FCC Rules. These limits are designed to provide reasonable protection against harmful interference when the equipment is operated in a commercial environment. This equipment generates, uses, and can radiate radio frequency energy and, if not installed and used in accordance with the instruction manual, may cause harmful interference to radio communications. Operation of this equipment in a residential area is likely to cause harmful interference in which case the user will be required to correct the interference at their own expense.

If in a residential setting you are encountering interference with TV and Radio reception while NOT in inverter mode, then: simply disconnect AC power from the TruePower Combi Charger/Inverter to confirm if this unit is causing the interference, if so explore the following options to minimize interference:

- 1) Make sure your AC connections include a proper Ground connection
- 2) Reposition your receiving antenna
- 3) Purchase a separate AC line filter
- 4) Relocate the affected appliance so it is further separated from the TruePower Combi Charger/Inverter

This equipment has been designed to comply with:

American Boat & Yacht Council A-31 Battery Chargers and Inverters
FCC Class A

Underwriters Laboratories: Standard 1236 Battery Chargers for Charging Engine Starter Batteries
Standard 458 Power Converter/Inverter Systems for Land Vehicles and Marine Crafts



⚠ DANGER

HIGH VOLTAGE
AVOID SERIOUS INJURY OR DEATH FROM ELECTRICAL SHOCK.
BEFORE PERFORMING ANY ELECTRICAL WORK TURN OFF AC POWER SUPPLY

⚠ DANGER

EXPLOSION HAZARD
AVOID SERIOUS INJURY OR DEATH
MAKE CONNECTIONS IN AN ATMOSPHERE FREE OF EXPLOSIVE FUMES

⚠ WARNING

LOW VOLTAGE
AVOID SERIOUS INJURY FROM ELECTRICAL BURNS AND SPARKS.
BEFORE PERFORMING ANY ELECTRICAL WORK DISCONNECT ANY DC POWER SUPPLY FROM UNIT

Warnings

⚠ CAUTION

HOT SURFACES – TO REDUCE RISK OF BURNS DO NOT TOUCH WHILE IN SERVICE
CHARGE ONLY USER SELECTED TYPE BATTERIES
(Flooded, AGM, Gel, or Calcium)
OTHER TYPES OF BATTERIES MAY BURST CAUSING PERSONAL INJURY AND DAMAGE
RISK OF ELECTRIC SHOCK, NO USER SERVICEABLE PARTS, RETURN TO MANUFACTURER FOR SERVICING
THIS UNIT IS IGNITION PROTECTED

SAVE THESE INSTRUCTIONS – This manual contains important safety, operating and installation instructions for these TruePower Combi models:

TruePower Combi - Combination Charger/Inverter

(110 VAC 60 Hz) 12 Volt QS Models

01012 True Power Combi Charger/Inverter - 110vac 60hz - 12Vdc - 40A
1000W Continuous/3000W Peak Surge

01512 True Power Combi Charger/Inverter - 110vac 60hz - 12Vdc - 40A
1500W Continuous/4500W Peak Surge

02412 True Power Combi Charger/Inverter - 110vac 60hz - 12Vdc - 50A
2500W Continuous/7200W Peak Surge

(110 VAC 60 Hz) 24Volt QS Models

01524 True Power Combi Charger/Inverter - 110vac 60hz - 24Vdc - 20A
1500W Continuous/4500W Peak Surge

02424 True Power Combi Charger/Inverter - 110vac 60hz - 24Vdc - 25A
2500W Continuous/7200W Peak Surge

(230 VAC 50 Hz) 12 Volt QS Models

01513 True Power Combi Charger/Inverter - 230vac 50hz - 12Vdc - 40A
1500W Continuous/4500W Peak Surge

02413 True Power Combi Charger/Inverter - 230vac 50hz - 12Vdc - 50A
2500W Continuous/7200W Peak Surge

(230 VAC 50 Hz) 24Volt QS Models

01525 True Power Combi Charger/Inverter - 230vac 50hz - 24Vdc - 20A
1500W Continuous/4500W Peak Surge

02425 True Power Combi Charger/Inverter - 230vac 50hz - 24Vdc - 25A
2500W Continuous/7200W Peak Surge

Warnings

TruePower Combi - Combination Charger/Inverter

(110 VAC 60 Hz) PS Models

02012	True Power Combi Charger/Inverter - 110vac - 60Hz - 12Vdc - 70A 2000W Continuous/6000W Peak Surge
02024	True Power Combi Charger/Inverter - 110vac - 60Hz - 24Vdc - 35A 2000W Continuous/6000W Peak Surge
(230 VAC 50 Hz) PS Models	
02013	True Power Combi Charger/Inverter - 20vac - 50Hz - 12Vdc - 70A 2000W Continuous/6000W Peak Surge
02025	True Power Combi Charger/Inverter - 230vac - 50Hz - 24Vdc - 35A 2000W Continuous/6000W Peak Surge

- ! Do not expose this unit to rain or snow
- ! Use of attachments not recommended or sold by Professional Mariner, LLC will void warranty and may result in the risk of fire, electrical shock or personal injury.
- ! Do not operate the unit if it has been dropped or visibly damaged in any way
- ! Do not disassemble the unit. If service or repair is required please contact ProMariner customer service at 1-800-824-0524
- ! To reduce the risk of electrical shock, remove connection to AC shorepower and DC connections prior to maintenance or cleaning. Turning off controls WILL NOT reduce this risk.

WARNING - RISK OF EXPLOSIVE GASSES

WORKING IN THE VICINITY OF A LEAD-ACID BATTERY IS DANGEROUS. BATTERIES GENERATE EXPLOSIVE HYDROGEN GAS DURING NORMAL BATTERY OPERATION. FOR THIS REASON IT IS OF UTMOST IMPORTANCE THAT EACH TIME BEFORE USING YOUR CHARGER YOU READ THIS MANUAL AND FOLLOW THE INSTRUCTIONS EXACTLY.

- ! To reduce the risk of battery explosion, follow these instructions and those published by the battery manufacturer and any equipment you intend to use in the vicinity of the battery(s). Carefully review the cautionary markings on this equipment.

Personal Safety Precautions

- ! **HELP** - Someone should be within the range of your voice or close enough to come to your aid when working with a lead-acid battery.
- ! **CONTACT** - Have plenty of soap and water nearby in case battery acid comes in contact with skin, clothes, or eyes. If battery acid contacts skin or clothing, wash immediately with soap and water. If acid enters eye, immediately flood eye with running cold water for at least 10 minutes and seek medical attention immediately.
- ! **WEAR** - Complete eye protection and protective clothing. Avoid touching eyes while working near battery(s).
- ! **NEVER** - Smoke or allow a spark or flame within the vicinity of the battery work area.
- ! **SPARK** - Be very cautious about dropping metal objects such as screwdrivers and wrenches onto a battery. This could short-circuit the battery and immediately cause a spark that may result in a fire or explosion.
- ! **REMOVE** - All personal metal items such as rings, watches, bracelets, etc. when working near a battery. A battery can produce a short circuit current high enough to weld a ring or any other metal causing serious burns.
- ! **DRY CELL BATTERIES** - Never use the battery charger feature to charge dry cell batteries that are commonly used with home appliances i.e. a cordless power drill battery. These batteries may burst and cause injury to persons and damage property.
- ! **FROZEN BATTERY** - Never charge a frozen battery.

Overview

UNPACKING AND INSPECTION

Thoroughly inspect your TruePower Combi unit. Take care in moving the unit as it weighs approximately 42 lbs.

The package should contain the following:

- 1) TruePower Combi unit
- 2) Parts package including:
 - a. + (Red) & - (Black) DC terminal covers and 8 (4 per cover) machine screws.
 - b. AC Terminal Cover and 2 strain relief connectors plus 2 screws
 - c. Remote package including panel, cable and mounting screws (if so equipped)
 - d. Owners/Installation manual

DAMAGE - If any parts are missing or damaged, or the unit has been damaged in shipping contact ProMariner customer service at 1-800-824-0524, do not take back to place of purchase.

DO NOT attempt to install or operate the unit if it has been damaged in any way.

Features

SMART TECHNOLOGY - Your new ProMariner TruePower Combi unit is current limiting with built in "smart" features to monitor vital functions and preclude damage to the charger and the installed system. The unit incorporates alarms, indicators and an auto shut-down feature for peace of mind and trouble free operation. This section contains descriptions of the LED indications and functions of controls. A more detailed description of LED and audible warning signals can be found in the Troubleshooting section. Turning the unit OFF and ON again will restart the unit after a fault, however, if the fault is still present, the unit will again shut down.

INVERTER - The TruePower Combi serves as a Pure Sine wave or a Quasi (modified) Sine wave inverter, converting DC power to clean, reliable AC power.

NOTE: This unit requires a large amperage draw from a DC battery when in Inverter mode. Care must be taken during installation to provide properly sized cables from the battery to the inverter. Cable runs must be as short as possible and of the appropriate size and type. See the Installation section for more details.

CHARGER - The TruePower Combi also serves as a high efficiency automatic battery charger suitable for all commonly available battery types (See Section 3 on the Features Table).

TRANSFER SWITCH - The TruePower Combi includes an internal, automatic 30 amp AC Transfer switch that senses the presence of AC shore/station power. Upon connection to a shore power/shore station source, the Combi will switch from INVERTER mode (providing AC power via DC battery source) to CHARGE mode, automatically. This switch, in compliance with ABYC E-11, disconnects the neutral AC lead from the AC ground when in shore/station power mode.

Features

- 1.Remote Panel Indicator LED's
- 2.Auto Standby/Off/On Switch

Battery Type Selector

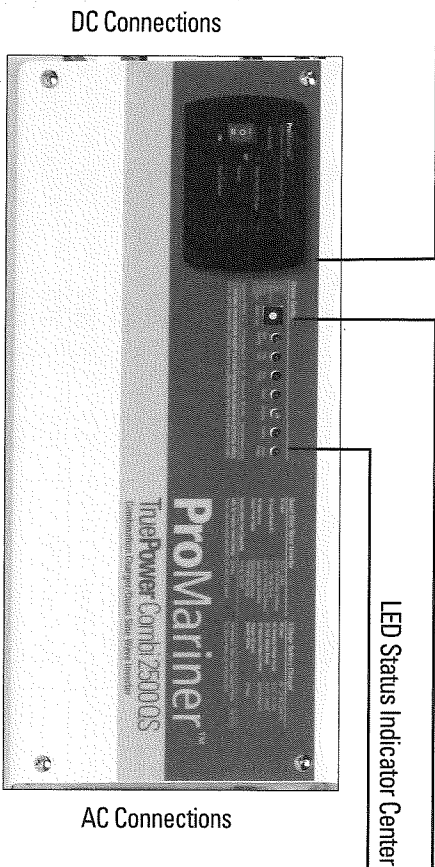

DC Connections

AC Connections

1. Remote Panel LED Indicators

Shore Station/ Power Charger	LED Color	Function When Illuminated
Inverter	Green	Shore/station power Connected/Charging
Fault Condition	Red	Inverter On/Shore/station power disconnected Fault Condition, See Troubleshooting Section

NOTE: This panel is removable from the TruePower Combi unit to be located in an area of greater convenience. A dummy plate is included in the package. See the Installation section for more details on removal of the remote panel and installation of the dummy plate.

2. Three Position Rocker Switch (Inverter feature ONLY)

Switch Position	Action
Auto Standby	Power on with Standby mode. Loads connected below 20W will NOT activate the Inverter
Power Off	Both the Inverter and the charger disabled.
Power On, Without Auto Standby	Power to Inverter is enabled, Auto Standby disabled.
Resetting the Unit After a Fault	Cycle power Off, then On again, the unit will reset. The unit will continue to shut down if the fault is present. In this event, consult the Troubleshooting section of this manual.

Features

3. Battery Type Selector					
Switch Setting	Description	Boost Charge Voltage		Float Charge Voltage	
		12V	24V	12V	24V
0	Factory set-up	N/A	N/A	N/A	
1	Gel 1	14.0	28.0	13.7	27.4
2	AGM 1	14.1	28.2	13.4	26.8
3	AGM 2	14.6	29.2	13.7	27.4
4	Sealed Flooded	14.4	28.8	13.8	27.6
5	Gel 2	14.4	28.8	13.8	27.6
6	Flooded	14.8	29.6	13.3	26.6
7	Calcium	15.1	30.2	13.6	27.2
8	Re-Condition	15.5	31.0	4 Hours, then Off	
9	Custom	N/A	N/A	N/A	N/A

4. LED Status Indicator Center		
LED Color	Function When Illuminated	
Auto Standby	Green	Auto Standby Mode
Over load	Red	Over Load Fault Condition
Over Temp	Red	Over Temperature Fault Condition
Ready	Green	Batteries are Charging in Float Charging Mode
Charging	Yellow	Batteries are Charging in Boost Charging Mode
Inverter	Green	Unit is in Inverter Mode
Shore/Station Power	Green	AC Shore/station power is connected

- 1. Remote Control Connection**
Provided for Optional Local Mounting of Status Panel and Operating Switch. (See Installation for more details)
- 2. DC Positive and Negative Connections**

Corrosion Resistant Mounting Studs, Provided with Multi-Directional Protective Cover. (See Installation for more details). These conductors provide power to the inverter from the battery and are also used for the charging feature when shore/station power is present.

NOTE: While your TruePower Combi does not require a fuse at the charger/inverter DC connections IT DOES require a fuse at the connection to the battery. This is supplied by the installer and is NOT included in this package. See the installation section for more details.

Features

- 3. Auto Cooling Fan**
Your TruePower Combi includes a Cooling Fan that is operational in both Invert and Charge mode. The fan keeps the TruePower Combi at an acceptable temperature. The fan operation is dependant upon unit temperature, charge current, and inverter load. There is no user requirements for proper fan operation, fan cycling is part of the units normal operation.
- 4. DC Grounding Conductor (Earth)**
An Additional corrosion resistant metal stud is provided for a connection to the installed DC Negative Bus, or Engine Negative Terminal. This is in compliance with ABYC A-31, the conductor used is allowed to be 1 size smaller than the positive conductor used. (See Installation for more details). This is an essential safety connection, do not attempt operation without this conductor properly installed.
- 5. Audible Warning**
As well as LED indications, the TruePower Combi includes and audible warning that accompanies the fault modes indicated in the LED status panel. For a detailed description of audible tones and duration see the Troubleshooting section

DC CONNECTION SIDE

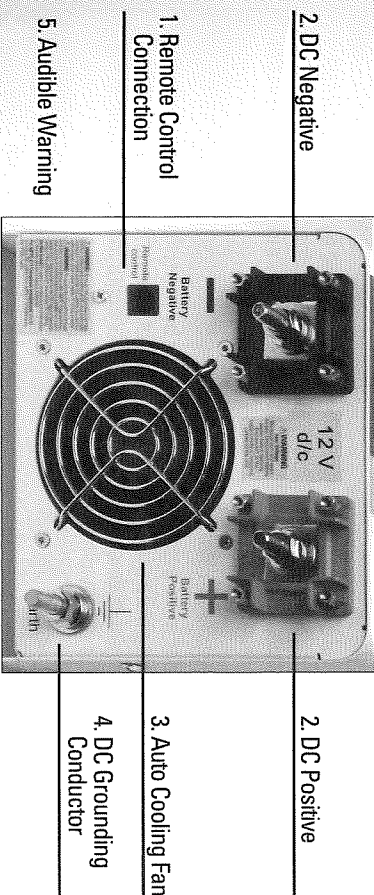

WARNING LABELS- These labels are indicated on the drawings so you can read and be familiar with their content before installation. Please read and understand the provided warnings. In the event of damage to the label that renders it unreadable, replacements are available by contacting Professional Mariner customer service at 1-800-824-0524, or www.promariner.com

- ⚠️ **WARNING**
Low Voltage: Electrical burn and spark hazard. Disconnect battery power before opening. Disconnect at the battery before removing cables at the unit.
- ⚠️ **WARNING:** To avoid risk of product damage and fire, inspect and confirm all DC stud and cable hardware is tight and the DC cables are secure with proper strain relief within 6" of the inverter.
- ⚠️ **WARNING:** To avoid risk of product damage and fire, in accordance with ABYC requirements, see your local marine/electrical installer for a wire gauge that is appropriate for the DC input amperage rating of this product for any added DC cabling.
- ⚠️ **Do Not Install** in wet or condensing humid areas or directly above or below batteries.
- For ABYC-E11 Compliant Installations install an inline DC safety fuse within 7' of battery on the (POS) cable

Features

AC CONNECTION SIDE

- 1. Charger Input Overcurrent Protection
- 2. Inverter Output Overcurrent Protection
- 3. AC OUTPUT Connections Ground (Green/Green w/yellow stripe) Line (Hot/Black) Neutral (White)
- 4. AC INPUT Connections Ground (Green/Green w/yellow stripe) Line (Hot/Black) Neutral (White)

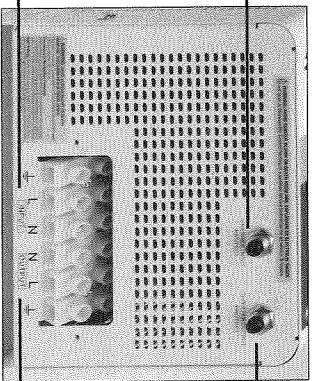

⚠ WARNING: AVOID SERIOUS INJURY OR DEATH FROM FIRE, EXPLOSION OR ELECTRICAL SHOCK.

This device must be connected to a Ground Fault Circuit Interrupter (GFCI) protected AC circuit. **This Device is Ignition Protected**
High Voltage: Avoid serious injury or death from electrical shock. Disconnect AC shore power and DC battery power to inverter before opening. Do not disconnect inverter under load.

⚠ WARNING: AVOID SERIOUS INJURY OR DEATH FROM FIRE, EXPLOSION OR ELECTRICAL SHOCK

Do not open or disassemble. Contact factory or a qualified service technician for all service & repairs.

1. Charger Input Overcurrent Protection

The Battery Charger feature on the TruePower Combi is protected by a thermal circuit breaker that disconnects power to the unit in the event of an overload. This must be manually reset after a period of time. Inability to reset the breaker indicates a fault in the system providing AC power to the unit.

2. Inverter Output Overcurrent Protection

The Inverter feature on the TruePower Combi is protected by a thermal circuit breaker that disconnects power coming from the inverter in the event of an overload. This must be manually reset after a period of time. Inability to reset the breaker indicates a fault in the system where the inverter is providing power.

3. AC Output Connections

These connections are provided for the AC Output FROM the Inverter feature. Any appliances, circuit panels or outlets will be connected via these conductors. See the installation section for placement of proper overcurrent protection to any devices connected to this source. These connections as well as the input connections are provided with a safety cover and strain relief.

4. AC Input Connections/Shore/station power

These connections are provided for the AC Input TO the Battery Charger feature. These connections are to be made from a properly protected conductor (e.g. a separate breaker on an AC panel board) to the TruePower Combi. The presence of AC current begins the charging cycle, as well as indicates to the whole system that the inverter is NO LONGER providing inverter power and is providing AC power as a pass-through. The Output connections must be connected to a properly sized AC breaker before powering any loads.

Setup and Operation

BATTERY TYPES - A word on Battery Types and the ProMariner TruePower Combi. As noted in the Battery Selection Table in the FEATURES section of this manual, this unit can handle 7 different types of commonly available batteries. Batteries are a consumable component and will, at some point, require replacement. Different batteries are charged with dramatically different charging profiles. A change in battery type upon replacement will require resetting of the battery type on the TruePower Combi unit. Identifying the battery type (available on the battery or by contacting the battery manufacturer) and setting the TruePower Combi accordingly is a crucial step in ensuring your batteries longevity. ProMariner has pre-programmed the available settings for optimum care of whatever type of battery you find suits your application.

DO NOT GUESS! If you are unsure of your battery type, contact the manufacturer of the battery.

BATTERY ISOLATION - When charging multi-battery banks it is recommended that a battery isolator or charging relay be installed. ProMariner offers several options to maintain isolation between batteries while charging.

OPERATING VOLTAGE - The TruePower Combi (depending on model chosen) will operate at voltages between 95 and 127VAC 50/60 Hz single phase. 230VAC models are also available in various configurations.

CHARGING RATES - The TruePower Combi charger provides 3 stage charging (bulk, absorption and float) as indicated in the Features section. The bulk or "boost" charge will operate for a maximum of 12 hours followed by a float charge. After 10 days of float, the charger again checks for the need to initiate the boost charge. The charger will repeat this cycle until it is unplugged when it will again start with the boost charge.

RECONDITION/EQUALIZATION - This feature is only recommended for traditional capped and vented lead acid type batteries. This process uses high voltage over a short period of time to remove sulphates from the batteries plates. The process "equalizes" the flooded cells and mixes the electrolyte. Your new TruePower Combi is programmed to perform this function without damage to your batteries.

STOP! BEFORE USING YOUR COMBI CHARGER/INVERTER READ AND FOLLOW THE BELOW CHECKLIST:

NOTE: Install by referring to the installation section of this manual OR, as recommended by ProMariner, have your TruePower Combi installed by a Certified ABYC Electrical Technician

- ✓ Begin with the power switch and main shore/station power breaker in the Off position.
- ✓ Ensure that all overcurrent protection (e.g. fuses and/or circuit breakers) are ready for use, not blown or tripped.
- ✓ Verify all connections are tight, corrosion free and of good integrity.
- ✓ With AC power applied (shore/station power main On), observe the following on the Status Indicator Center and the Remote Panel:

Setup and Operation

LED Status Indicator Center – CHARGER MODE

Feature	LED Color	Function
Auto Standby	N/A	
Over load	N/A	
Over Temp	N/A	
Ready	GREEN	Illuminated during FLOAT charge
Charging	YELLOW	Illuminated during BOOST charge
Inverter	N/A	
Shore/Station Power	Green	

VERIFY THE REMOTE PANEL LEDS ARE AS FOLLOWS:

Remote Panel LED Indicators – CHARGER MODE

	LED Color
Shore/Station Power/Charger	GREEN
Inverter	N/A
Fault Condition	N/A

NOTE: This LED configuration indicates that the charger feature is functioning normally and does not need any further attention. If the RED "Fault Condition" LED illuminates, consult the Troubleshooting section of this manual.

INVERTER MODE START-UP:

- ✓ After following the above charger instructions, confirm the rocker switch on the remote panel is in the Off position.
- ✓ Turn off the AC main shore/station power breaker.
- ✓ If using a split-bus installation (see Installation section of this manual) turn off all branch circuits associated with the inverter.
- ✓ If powering the entire panel with the TruePower Combi, turn off all branch circuits.
- ✓ Switch the remote panel rocker switch to On.
- ✓ Observe the following on the Status Indicator Center and the Remote Panel:

Setup and Operation

LED Status Indicator Center – INVERTER MODE

	LED Color
Auto Standby	N/A
Over load	N/A
Over Temp	N/A
Ready	GREEN
Charging	YELLOW
Inverter	GREEN
Shore/Station Power	GREEN

VERIFY THE REMOTE PANEL LED'S ARE AS FOLLOWS:

Remote Panel LED Indicators – INVERTER MODE

	LED Color
Shore/Station Power/Charger	N/A
Inverter	GREEN
Fault Condition	N/A

BEGIN ENERGIZING THE AC CIRCUITS CONNECTED TO THE INVERTER:

- ✓ Confirm the LED configuration continues to match the above table.
- ✓ Confirm operation of all GFCI outlets and/or breakers attached to inverter power.
- ✓ For any other LED configuration see the Troubleshooting section of this manual.

OPERATIONAL NOTE: Your TruePower Combi has built in safety features that can cause the unit to shut down if it senses out of parameter operations such as over-voltage and high temperatures. See the troubleshooting section of this manual for more details in the event this occurs.

INVERTER OPERATIONAL CONSIDERATIONS

The TruePower Combi can be used to power any number of AC appliances normally only available to you while hooked to shore/station power or operating a generator. Appendix A includes a load calculation sheet from ABYC E-11 AC & DC Electrical Systems on Board Boats. Below are typical appliances and their load ratings:

Setup and Operation

TruePower Series Inverter Mode Selector Guide

Application	Wattage	1000 Watts	1500 Watts	2000 Watts	2500 Watts
Large Air Conditioner	2100				
Refrigerator/Freezer	2000				
Hair Dryer	1700				
Refrigerator	1500				
1/2 HP Submersible Sump Pump	1400				
Disk Sander	1200				
Toaster Oven	1000				
Small Microwave Oven	1000				
6" Circular Saw	950				
Coffee Maker	800				
3/8" Reversible Drill	750				
Mixer/Blender/Food Processor	650				
Small Air Conditioner	600				
Portable Vacuum	550				
Small Refrigerator	500				
1/4" Drill	400				
HiFi Stereo	350				
19" Color TV	175				
Halogen Worklight	100				
Laptop Computer	100				
13" Color TV	80				
Cellular Phone Charger	25				

The items listed above are for reference only. In order to compute the actual wattage of a device, determine the Amps the device is rated at and then Multiply the Amps x Volts = Watts. For example: 10A x 120V = 1200 Watts.

Or select the number of devices listed above you intend to use and add the Wattage of each device to give you an estimated total. Select a model that is equal or greater than the total.

These load ratings are for guidance only, check your specific needs and compare to the maximum rating on your new TruePower Combi unit.

DC POWER DRAW – Remember: The inverter consumes DC battery power to supply the AC loads; it's not recommended that large appliances such as electric stoves and water-heaters be run via the TruePower Combi inverter. The TruePower does include low battery protection to prevent complete discharge of your DC system. It is extremely difficult to predict how long the attached DC battery bank (no matter what size or type) will sustain the use of the inverter connected loads. This must be done on a trial and error basis. ProMariner recommends that once a comfortable load is established, that notes are added to

Setup and Operation

the end of this manual for future reference. This load vs. time ratio will change as batteries age or are replaced.

START UP CURRENT (INRUSH) - Many motor operated appliances have a higher wattage requirement to get started than while running. This is called "inrush" current. Your TruePower Combi unit is capable of running 2.8 times its rated current for this reason. If an appliance requires more than the rating of the TruePower Combi, or within the rating for a longer duration than 10 seconds the unit will shut down. Resetting the unit is achieved by clearing the 3 position rocker switch to the Off position. The unit will then self-check and clear the fault. The appliance should be tried multiple times before determining that its draw is too large for the TruePower Combi unit to handle, no damage will result with multiple attempts. See the Troubleshooting section of this manual for more detailed fault information.

MULTIPLE APPLIANCES – Similar to the inrush current discussed above, care should be taken to stagger the start-up of multiple loads. It is possible to exceed the overload of the capacity upon start-up of multiple appliances even though, combined, their ratings do not exceed the rating of the unit. Resetting the unit is achieved by selecting the Off position on the 3 position rocker switch. The unit will then self-check and clear the fault. See the Troubleshooting section of this manual for more detailed fault information.

RECHARGING BATTERIES – ProMariner recommends that batteries are recharged before they are fully discharged. This practice will ensure the longest possible lifespan of your batteries. It is recommended that a Remote Battery Status Indicator is used to monitor your battery bank.

Installation

NOTE: ProMariner highly recommends that this unit be installed by an ABYC Certified Electrical Technician. Guidance from ABYC E-11 AC & DC Electrical Systems on Board Boats and ABYC A-31 Battery Chargers & Inverters is offered throughout this manual to ensure a safe, trouble free installation. Please re-read the PERSONAL PRECAUTIONS section of this manual prior to installation.

LOCATION – This unit must be located in a dry, well ventilated area, free from unsecured hardware. Unit must be floor or wall mounted horizontally only. Do not install Vertically. Do not install any wiring /cables under the unit. Do not mount on carpet or flammable surfaces. Do not mount in areas where humidity will exceed 90% non condensing. Temperature is also a serious consideration. Do not mount this unit in areas where temperatures will exceed 40° C (104° F). Generally this includes engine compartments where operating temperatures are often exceeded substantially by temperatures after shutdown when airflow is lessened due to the lack of combustion air required.

LOCATION – This unit is IGNITION PROTECTED, therefore it may be mounted in a location containing:

- 1) Gasoline powered machinery (e.g. engine or generator), or
- 2) Gasoline fuel tank(s), or
- 3) Joint fittings (e.g. fuel filters, valves) or,

Installation

4) Other connection(s) between components of a gasoline system (e.g. vent and fill lines).

LOCATION – In addition, the following should be considered when choosing a location:

- 1) Placement of the remote status panel - A length of communications cable is provided for remote-location of the status/on/off/standby panel. Ensure the cable is long enough to reach the desired location (generally in proximity to the main panel board) and is not routed near exhaust or in an area where it can be damaged.
- 2) Service - Remember, there are items on this unit that should be routinely checked (connections, LED Status Center) to ensure that there is ample room to address these issues. Also consider space to adequately swing a standard wrench. Contact between a live component and a metallic fuel line can be extremely dangerous.
- 3) Cable Routing - Large DC cables and overcurrent protection (fuses/circuit breakers) will be located in proximity to this unit. Choose a location as CLOSE AS POSSIBLE to the DC battery bank serving the unit. This will provide optimum performance for the unit and keep cable sizes smaller. Location of the AC power is less critical than the DC supply. More information on cable sizing follows.
- 4) Battery Location - This unit can not be mounted directly above or below a battery due to the corrosive nature of the gasses and electrolyte. Take care to ensure that spillage of electrolyte can be contained in a box or tray in the event of a leak and that the corrosive gas given off during the use and charge cycles cannot come into contact with the unit.

MOUNTING - This unit is heavy (around 42 pounds) and must be mounted securely to an appropriate surface (e.g. plywood bulkhead, cored fiberglass hull structure) and through-bolted if possible. ProMariner highly recommends using mounting holes other than just the key slots for mounting.

The following are the dimensions for the TruePower Combi:

Installation

1.18" / 3 cm wide - 2.17" / 5.5 cm on center

1.18" / 3 cm on center

Dia. .27" / .675cm

2.01" / 5.1 cm

2.36" / 6 cm

1.08" / 2.75 cm

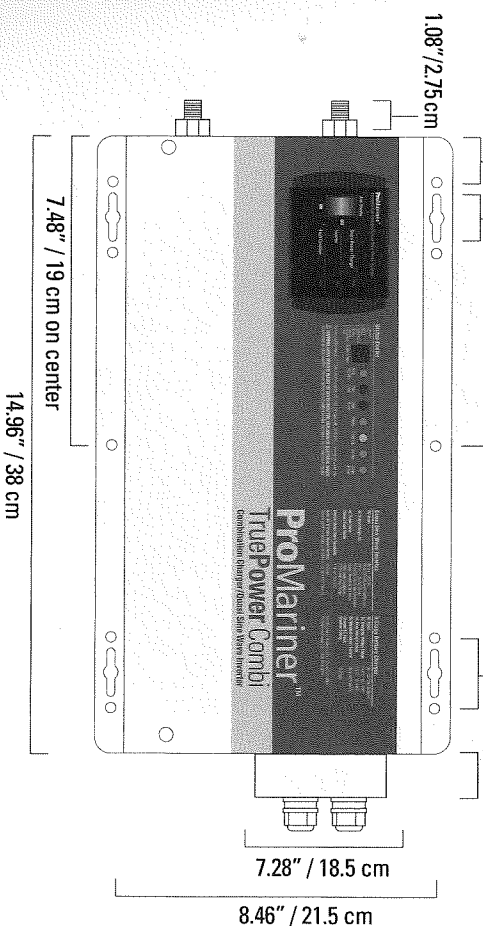

Installation NOTE: Unit must be floor or wall mounted horizontally only. Do not install vertically. Do not install any wiring/cables under the unit. Do not mount on carpet or flammable surfaces. Do not mount in areas where humidity will exceed 90% non condensing.

Remote Panel re-location – The remote panel can easily be removed from the TruePower Combi unit and positioned in a more convenient location.

1) Slide the side molding outward from the panel

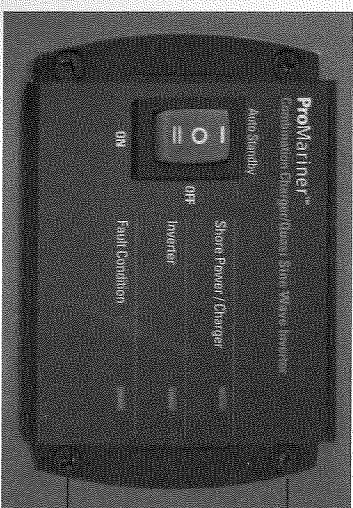

1. Side Molding Removed

2. Philips-Head Screws Exposed

2) Remove 4 Philips-head screws securing the unit to the Combi.

Installation

3) Disconnect the short pigtail from inside the TruePower Combi.

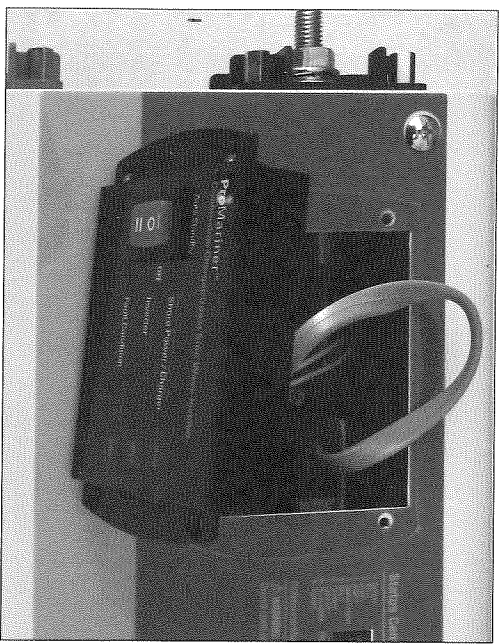

1. Network-Type Cable Connection

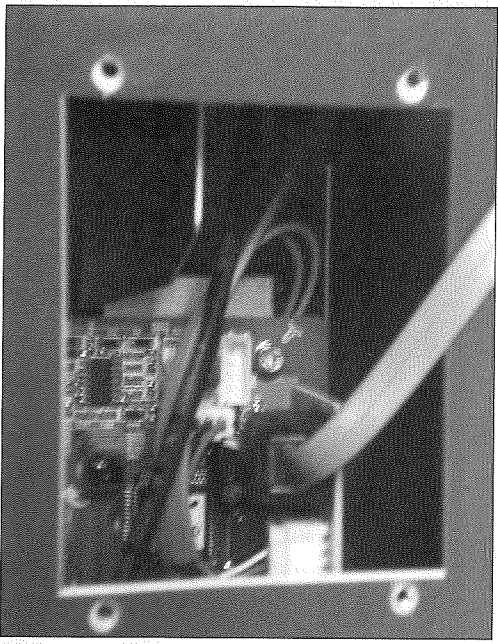

Network-Type Cable Connection DETAIL

1) Install the provided dummy panel in the reverse order in which the remote panel was removed.

Installation

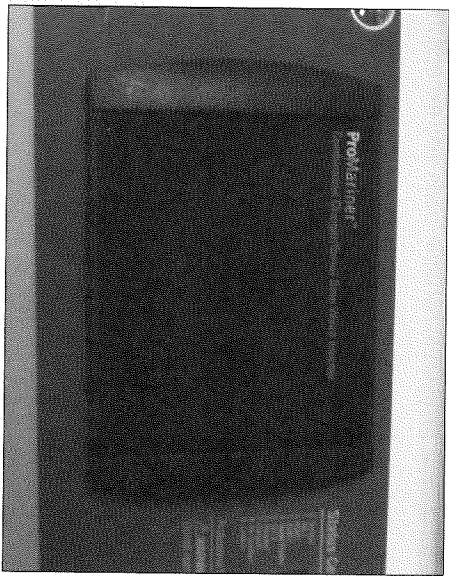
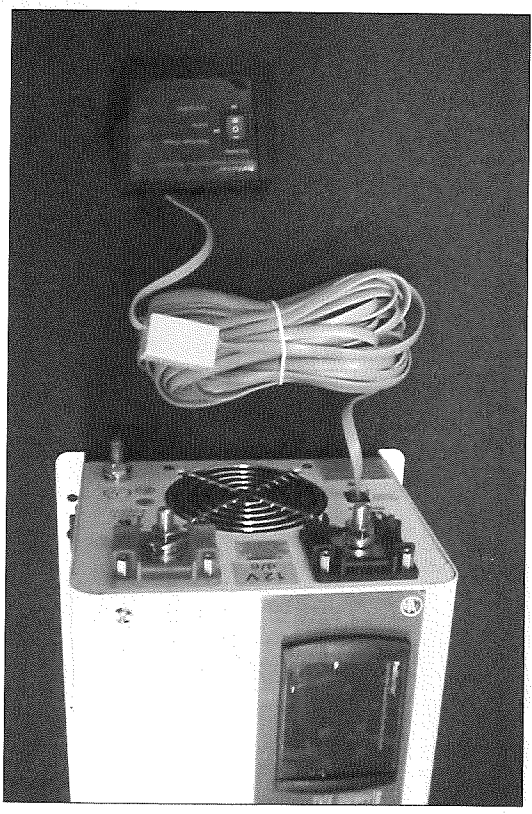

1) Locate remote panel and prepare an appropriately sized mounting location (75mm x 44mm or 3" x 1-3/4"). A connector and extension cable are provided. The extension cable is to be connected to the external connection as indicated in the FEATURES section.

AC Wiring Options

⚠ WARNING - AC Installations have the potential to cause serious injury or death, installations should be performed by an ABYC Certified Electrical Technician to ensure a safe and trouble free installation.

Depending on the appliances & loads that are intended to be powered by the TruePower Combi, there are essentially 3 installation options:

- 1) SPLIT BUS – This option allows only certain circuits to be energized by the TruePower Combi. There are several points to make a note of in the following drawing provided from ABYC found in A-31 Battery Chargers & Inverters:
 - a. The TruePower Combi acts as a pass through, the AC inputs are fed from ANY AC power source, Shore or Generator. The input to the TruePower Combi must be tapped from power AFTER any installed transfer switch.
 - b. In this scenario, the complete Main AC Panel WOULD NOT be powered by the TruePower Combi. Either an additional AC Subpanel can be installed (constantly powered by the Shore/Generator pass-through or, when in Invert mode, exclusively powered by the TruePower Combi) OR the existing AC Panelboard bus can be split into essentially 2 parts with only 1 part HOT during Invert mode.

Advantages – The split bus scenario ensures that the TruePower Combi is not overloaded by installed loads. (of course, plugged-in portable loads may exceed the wattage rating if not controlled)

Installation Diagrams

TruePower Charger/Inverter Installed with a Split-Bus System

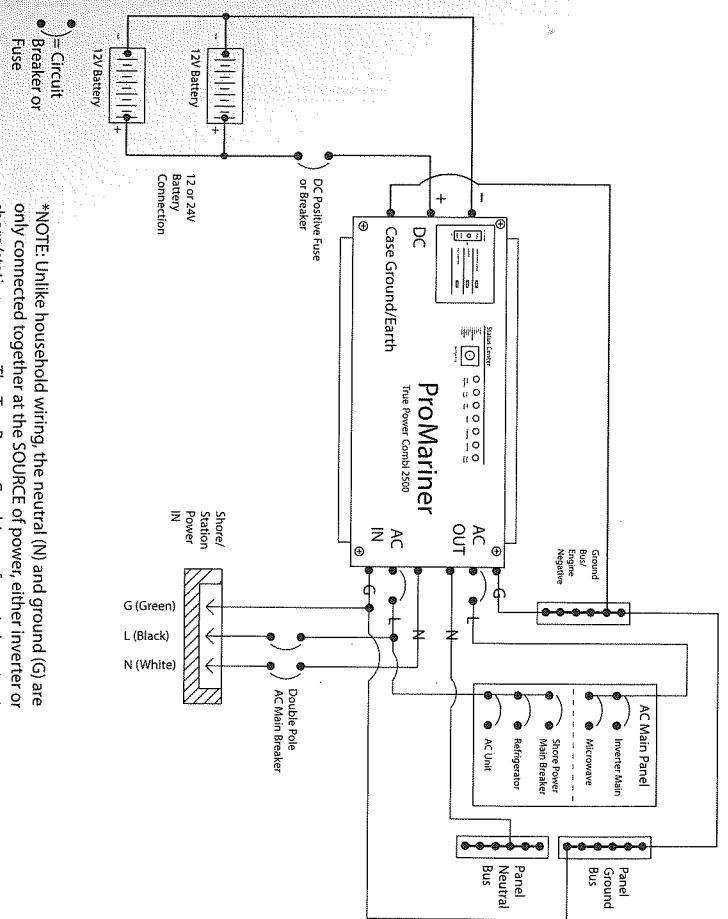

*NOTE: Unlike household wiring, the neutral (N) and ground (G) are only connected together at the SOURCE of power, either inverter or shore/station power. The TruePower Combi transfer switch maintains this wiring scheme automatically.

Installation Diagrams

TruePower Combi Installed to Power a Full AC Panelboard - Transfer to All Loads

2) TRANSFER TO ALL LOADS – This scenario allows the entire AC panelboard to be powered by the TruePower Combi. This is the simplest installation for an existing AC panelboard. This scenario enables the user to choose what will be powered by the TruePower Combi. Energizing the entire panel may overload the unit depending on the size and the load requested. The diagram below provided from ABYC found in A-31 Battery Chargers & Inverters

Advantages - Multiple loads from the existing panelboard can be chosen, the user is not locked into set loads. This may require more trial and error to determine which loads the TruePower Combi can run.

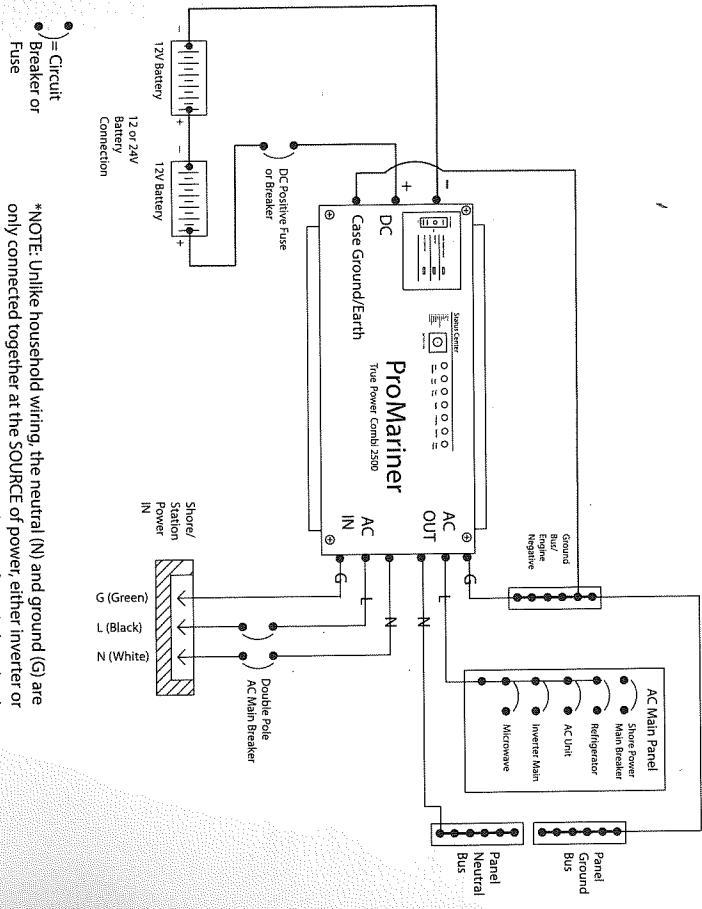

*NOTE: Unlike household wiring, the neutral (N) and ground (G) are only connected together at the SOURCE of power, either inverter or shore/station power. The TruePower Combi transfer switch maintains this wiring scheme automatically.

Installation Diagrams

True Power Combi Installed to Power Dedicated AC Device

3) DEDICATED APPLIANCE – This scenario is becoming popular with items like air conditioning units and refrigerators where the load of the appliance and the rating of the inverter are matched. With this type of installation, the inverter is dedicated to only one load, whether in invert or pass-through mode.

Advantages – With this installation type there is never an issue with overloading of the inverter capacity.

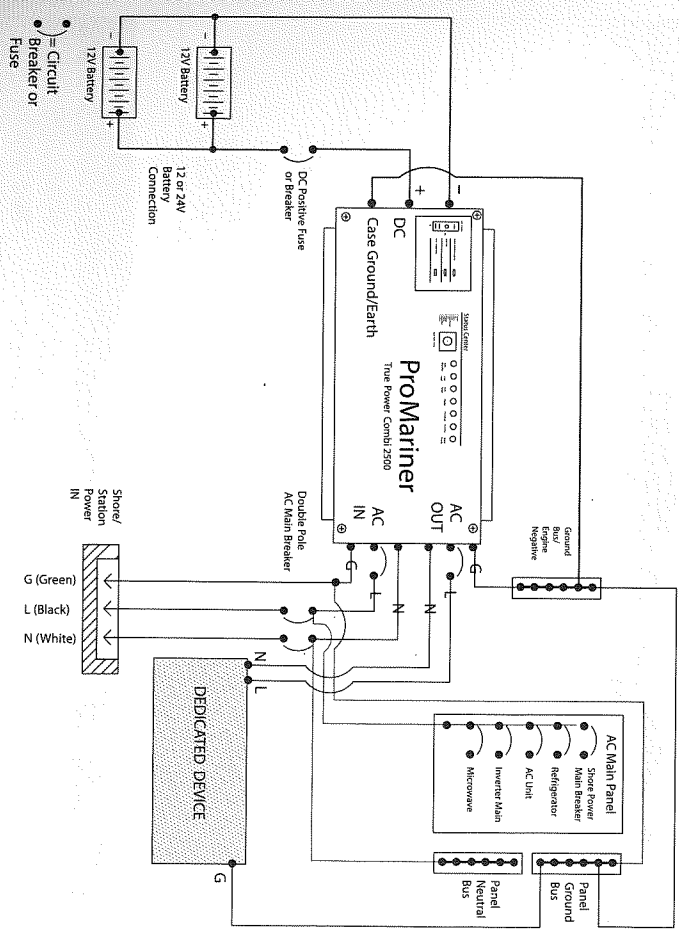

*NOTE: Unlike household wiring, the neutral (N) and ground (G) are only connected together at the SOURCE of power, either inverter or shore/station power. The TruePower Combi transfer switch maintains this wiring scheme automatically.

Connections

AC IN		
Marking	Description	Color
L	Line or Hot	Black
L2	Line 2 or Hot on 220 VAC applications only	Red
N	Neutral	White
G	AC Ground	Green or Green w/ Yellow Stripe
AC OUT		
Marking	Description	Color
L	Line or Hot. (Black). To 110 VAC powered appliances (main panelboard or split bus or L1 loads on 220 VAC)	Black
L2	Line 2 or Hot on 220 VAC applications only (Red). To 110 VAC powered appliances (main panelboard or split bus or L2 loads on 220 VAC)	Red
N	Neutral (White) <i>NOTE: This Neutral shall not be connected to the ground other than at the designated power source (e.g. TruePower Combi, Shore/station power, generator). The internal transfer switch in this unit maintains isolation until connected. Ensure that existing transfer strategies do the same.</i>	White
G	AC Ground	Green or Green w/ Yellow Stripe

DC IN/OUT		
Marking	Description	Color
+	Battery Positive = Positive Battery charge lead as well as power feeder for invert mode	Red
-	Battery Negative = Negative Battery charge lead as well as negative return for invert mode.	Black or Yellow
Earth	Safety Ground connected to the boats DC grounding bus. This conductor is essential to shock and fire prevention and carries current as a result of a fault. AC Ground	Green or Green w/ Yellow Stripe

Installation

! DO NOT OPERATE THIS UNIT WITHOUT THE EARTH CONNECTION ATTACHED.

The earth conductor is permitted to be 1 size smaller than the DC Positive (+) conductor (Example: DC += 2 AWG, Earth = 4 AWG)

DC POWER SUPPLY

ProMariner Minimum Recommended Battery or Battery Bank is 200 Ahr.

Series vs. Parallel - 2 types of battery connections exist, either installation can be used with the TruePower Combi.

Series - Batteries connected in order to boost voltage while maintaining amp-hour ratings.

Parallel - Batteries connected in order to boost amp hours while maintaining voltage.

The two scenarios are easily illustrated:

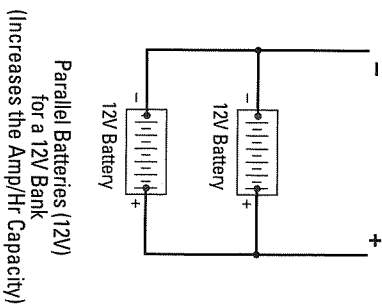
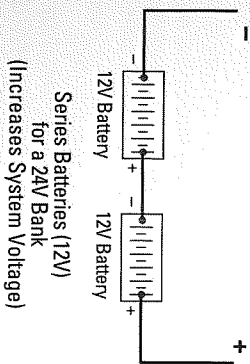

INSTALLATION MATERIALS – CABLING

1) DC Cables - The DC portion of the TruePower Combi requires a large amount of amperage in Inverter Mode. Cable size and length is of extreme importance and should be well thought out and planned per this manual before beginning installation. Items to consider are as follows:

- a. Cable Size - Size is based on amperage draw of the unit compared to the maximum amperage a cable can carry based on ABYC E-11. ProMariner recommends **NO MORE THAN** a 10% drop in voltage from source (battery)/to the TruePower Unit or a cable run longer than 5 feet. The following table outlines the cable size based on unit size.

Recommended Cable Sizes

(Based on UL 1426 105° C Jacket Temperature Rating)

Installation

Inverter Wattage	12 Volt DC Amp Draw	24 Volt DC Amp Draw	Minimum Cable Size(AWG) 12V*	Minimum Cable Size(AWG) 24V*
1000	100A	N/A	4	N/A
1500	150A	75A	2	6
2000	200A	100A	0	4
2500	250A	125A	00	4

*Based on ABYC E-11 2008 Table VI-A Inside Engine Spaces.

b. Termination - Larger DC cables require specialty tools to ensure proper termination with ring terminals. Pre-terminated cable kits can be purchased through ProMariner or your local marine supply store. The DC stud size is 5/16". Cable type is as important as size. Cables must be marine grade and acceptable under ABYC E-11 AC & DC Electrical Systems on Board Boats (types such as UL 1426 Boat Cable, and SAE J1127 Battery Cable are common and marked as such)

c. Connection – The ring terminal must be directly on the battery terminal surface of the DC studs on the TruePower Combi, followed by the washer and nut with a torque of 10-15 foot-pounds. The use of a dielectric or anti-oxidant paste is recommended once the cables have been connected.

I DO NOT ATTEMPT CABLE TERMINATION BY MEANS OTHER THAN PROPER CRIMPING, WITH A PROPERLY CALIBRATED TOOL. SOLDER AND AUTOMOTIVE REPAIR TYPE BATTERY TERMINALS ARE NOT ACCEPTABLE. USE OF ANY OF THESE TYPES OF TERMINATIONS WILL RESULT IN PREMATURE, UNWARRANTED FAILURE OF THE TRUEPOWER COMBI UNIT.

2) AC Cables – AC Cables should be UL 1426 Boat Cable, per ABYC E-11. This type of cable is readily available in both 2 and 3 conductor. Size is based on the maximum amperage to be passed through the cable and unlike DC does not take into account the length of the cable run and voltage drop. The table below indicates the proper size for AC Cables.

a. AC Connections – Screw terminals have been provided to connect the input and output AC cables.

Shore/station power Service	Cable Size (AWG) 105° C Insulation
30 amp	12
50 amp	10

Installation

INSTALLATION MATERIALS – OVERCURRENT PROTECTION (Fuses and or Breakers)

DC Cable Protection – The purpose of overcurrent protection is to protect the wire from conducting too much amperage. Fuses and circuit breakers are adequate for this purpose. The TruePower Combi is protected at the source for charging purposes internally to the unit. The installer must provide overcurrent protection within 7" of the point of connection to the positive terminal of the battery. The appropriate amperages are provided below for both 12 and 24 volt models:

ANL Ignition Protected Fuses for TruePower Models 12V			
Amperage	Single Position ANL Fuse Holder	1000 Watt	1500 Watt
100-425 amps		130 amp	175 amp
			300 amp

ANL Ignition Protected Fuses for TruePower Models 24V			
Amperage	Single Position ANL Fuse Holder	1500 Watt	2500 Watt
100-425 amps		100 amp	175 amp

TERMINAL PROTECTION & STRAIN RELIEF

AC Terminals must be protected with the provided cover. This cover also includes grommets to provide local strain relief on the conductors. The conductors shall also be secured to structure within 18" of the unit by other means such as straps or wire ties.

DC Terminals must be protected with the provided covers. The covers allow for multi directional cable installation and should be installed to match the direction of the incoming cable. The conductors shall also be secured to structure within 18" of the unit by means such as straps or wire ties.

MAIN PANELBOARD

A True RMS voltmeter must be installed on or in proximity to the main panelboard along with the following label included with the TruePower Combi:

WARNING

Electrical Shock Hazard

Vessel is equipped with a DC to AC power inverter
Disconnect inverter DC input before servicing vessel's electrical systems.

Post Installation

POST INSTALLATION PRE-START CHECKLIST:

VERIFY:	✓
Proper AC connections	
L1, L2, N, G, at the TruePower Combi and main AC Panelboard	
Proper DC Connections	
Battery +, Battery -, Earth at the TruePower Combi and at the battery and grounding bus.	
TruePower Combi remote panel switch is in the OFF position	
Battery Voltage is within operating specifications 10.0 VDC – 15.5 VDC	
Battery Type Selector switch has been properly set	
Presence of AC Power Shore/station power Connected	
Status of fuses/circuit breakers. Fuses in holders, breakers in on position, main AC breaker OFF.	

CHARGER FEATURE START UP

Turn on AC main breaker	✓
Verify proper condition of LED indicators per Table 4 in Features section	

INVERTER FEATURE/TRANSFER SWITCH

START UP	✓
Turn OFF AC main breaker	
Turn OFF TruePower Combi remote panel switch	
Disconnect shore/station power cable	
Turn off all loads associated with the TruePower Combi inverter	
Turn ON AC main breaker	
Verify proper condition of LED indicators per Table 4 in Features section	
Begin applying intended and/or connected loads to the TruePower Combi by turning on breakers one at a time.	
<i>NOTE: Be aware of motor loads with significant start-up amperages such as refrigerators and other motor circuits, be sure that these have started and are properly running before applying additional motor loads.</i>	
Test any connected GFCI outlets for proper function when connected to the TruePower Combi unit.	

Maintenance

This unit is solid state and requires no constant adjustment or constant attention, however, the following items should be checked:

Maintenance Item	Start Up	Monthly
Verify LED Status Panel shows no fault condition and indicates normal operation.	✓	
Condition of fuses/breakers check for as-new condition on fuses (e.g. no discoloration or corrosion) and that a breaker will manually trip and reset.	✓	
Check for proper ventilation and that no debris has collected on the fan shroud or items have been improperly stored around the inverter.	✓	
Check battery terminal connections (both at battery and TruePower Combi) for corrosion. Immediately upon signs of corrosion clean with distilled water and reconnect. Use of tap or bottled drinking water will damage battery plates due to mineral content.		✓
Per manufacturer's instructions, check and top off batteries		✓
Check wire condition, overheating due to excessively long or too small conductors will result in hardening of the insulation or even burn marks at connections. If any of these signs exist, immediately remedy the situation by installing the proper conductors.		✓

Troubleshooting

The TruePower Combi includes advanced fault indication. The following table outlines LED and buzzer warning combinations. Some of these faults, if exist, require service from ProMariner.

The first step to any problem is resetting the TruePower Combi unit by turning off and then on the switch located on the remote panel.

THERE ARE NO USER SERVICEABLE PARTS INSIDE THE TRUEPOWER COMBI UNIT. DO NOT ATTEMPT TO DISSASSEMBLE THE UNIT. EVIDENCE OF DISSASSEMBLY WILL VOID MANUFACTURERS WARRANTY.

▶ Troubleshooting

INDICATOR AND ALARM MODE SETTING

X - Indicates NO LED Illuminated

✓ - Indicates LED Illuminated

Item	LED Status Center Indication	LED on Remote				Buzzer
		Power saver on	Battery charger	Inverter	Alarm	
Battery Low	X	✓	X	X	✓	BEEP 0.5 SEC FOR 5 SEC.
Battery High	X	✓	X	X	✓	BEEP 0.5 SEC FOR 1 SEC.
Overload on Invert Mode	X	✓	X	✓	✓	BEEP 0.5 SEC FOR 1 SEC.
Over Temp on Invert Mode	X	✓	X	✓	✓	BEEP 0.5 SEC FOR 1 SEC.
Over Temp with AC Pass Through	✓	X	✓	X	✓	BEEP 0.5 SEC FOR 1 SEC.
Over Charge	✓	X	✓	X	✓	BEEP 0.5 SEC FOR 1 SEC.
Fan Lock	X	X	X	X	X	BEEP CONTINUOUS
Battery High	X	✓	X	X	X	BEEP CONTINUOUS
Overload on Invert Mode	X	X	X	✓	X	BEEP CONTINUOUS
Over Temp	X	X	X	✓	X	BEEP CONTINUOUS
Over Charge	X	X	✓	X	X	BEEP CONTINUOUS
Back Feed	X	X	X	X	X	BEEP CONTINUOUS

▶ Appendix 1 Load Calculations

In order to calculate the kVA necessary for your application, use the following formula from ABYC E-11:

$$kVA = \frac{\text{Maximum Total Leg Amps} \times \text{System Voltage}}{1000}$$

The Maximum Total Leg Amps can be calculated using the following worksheet from ABYC E-11:

11.8.2.2.1 Lighting Fixtures and Receptacles - Length times width of living space (excludes spaces exclusively for machinery and open deck areas) times 2 watts per square foot (20 watts per square meter).

Formula:

$$\text{Length (feet)} \times \text{width (feet)} \times 2 = \text{lighting watts, or}$$

$$\text{Length (meters)} \times \text{width (meters)} \times 20 = \text{lighting watts.}$$

11.8.2.2.2 Small Appliances - Galley and Dinette Areas - Number of circuits times 1,500 watts for each 20 ampere appliance circuits.

Formula:

$$\text{Number of circuits} \times 1,500 = \text{small appliance watts.}$$

$$11.8.2.2.3 \quad \text{Total Load}$$

Formula:

$$\text{Lighting watts plus small appliance watts} = \text{total watts.}$$

$$11.8.2.2.4 \quad \text{Load Factor}$$

Formula:

$$\text{First 2,000 total watts at 100\%} =$$

$$\text{Remaining total watts} \times 35\% =$$

$$\text{Total watts divided by system voltage} = \text{amperes.}$$

11.8.2.2.2 If a shore power system is to operate on 240 volts, split and balance loads into Leg A and Leg B. If a shore power system is to operate on 120 volts, use Leg A only.

11.8.2.2.3 Add nameplate amperes for motor and heater loads:

Appendix 1 Load Calculations

LEG A	LEG B
	Total Amperes
	Exhaust and supply fans
	Air conditioners,***
	Electric, gas or oil heaters*
	25% of largest motor in above items
	Sub-total

NOTES:

* Omit smaller of these two, except include any motor common to both functions
 *** If system consists of three or more independent units adjust the total by multiplying by the 75% diversity factor

11.8.2.2.1 Add nameplate amperes at indicated use factor percentage for fixed loads:

LEG A	LEG B
	Disposal -10%
	Water Heater - 100%
	Wall Mounted Ovens – 75%
	Cooking Units - 75%
	Refrigerator -100%
	Freezer – 100%
	Ice Maker - 50%
	Dishwasher - 25%
	Washing Machine – 25%
	Dryer - 25%
	Trash Compactor – 10%
	Air Compressor - 10%
	Battery Chargers – 100%
	Vacuum System - 10%
	Other Fixed Appliances
	Sub-Total
	**Adjusted Sub-Total

NOTE: **If four or more appliances are installed on a leg, adjust the sub-total of that leg by multiplying by 60% diversity factor.

Appendix 1 Load Calculations

11.8.2.2.1 Determine Total Loads

LEG A	LEG B
	Lighting, receptacles, and small appliances (from E-11.8.2.2.1, E-11.8.2.2.2)
	Motors and heater loads (from E-11.8.2.2.3)
	Fixed appliances (from E-11.8.2.2.4)
	Free standing range (See NOTE 1)
	Calculated total amperes (load)

NOTES:

1. Add amperes for free standing range as distinguished from separate oven and cooking units. Derive by dividing watts from Table III by the supply voltage, e.g., 120 volts or 240 volts.
 2. If the total for Legs A and B are unequal, use the larger value to determine the total power required

NAMEPLATE RATING (WATTS)	USE (WATTS)
10,000 or less	80% of rating
10,001 – 12,500	8,000
12,501 – 13,500	8,400
13,501 – 14,500	8,800
14,501 – 15,500	9,200
15,501 – 16,500	9,600
16,501 – 17,500	10,000

Appendix 2 Technical Specifications

INVERTER SPECIFICATIONS

TruePower Combi	1000 QS	1500 QS	2500 QS	2000 PS
Power	1000W	1500W	2400W	2000W
Continuous Power	1000W	1500W	2400W	2000W
Surge Power	3000W	4500W	7200W	6000W
Output Waveform	Modified Sine Wave			Sine Wave
AC Output Voltage	110	110/230	110/230	110/230
DC Input Voltage	12	12/24	12/24	12/24
Efficiency	>80%			
Cooling Fan	Yes			
Short Circuit Protection	Yes			
Soft Start	Yes			
High Voltage Protection	Yes			
Reverse Polarity Protection	Yes			
Capable of Starting Electric Motor	1/2 hp	1/2 hp	1 hp	1 1/2 hp
Low Battery Alarm	10.5Vdc ± b1 0.3Vdc for 12V battery 21Vdc ± b1 0.6Vdc for 24V battery			
Low DC Input Shut Down	10.Vdc ± b1 0.3Vdc for 12V battery 20Vdc ± b1 0.6Vdc for 24V battery			
High DC Input Alarm & Fault	16Vdc ± b1 0.3Vdc for 12V battery 32Vdc ± b1 0.6Vdc for 24V battery			
High DC Input Recovery	15.5Vdc ± b1 0.3Vdc for 12V battery 31Vdc ± b1 0.6Vdc for 24V battery			
Power Saver	Load <20W (enabled on "stand by" setting of Remote Panel)			

CHARGER SPECIFICATIONS

TruePower Combi	1000 QS	1500 QS	2500 QS	2000 PS
Input Voltage	120V			
Nominal Charge	40A-12Vdc	40A-12Vdc	50A-12Vdc	70A-12Vdc
	20A-24Vdc	25A-24Vdc	35A-24Vdc	
Charge Current Regulation	± 5Adc			
Battery Initial Voltage	0-15.7Vdc (can operate w/ 0Vdc battery)			
Charger Breaker Size	16A	20A	20A	30A

Appendix 2 Technical Specifications

AC PASS-THROUGH SPECIFICATIONS

TruePower Combi	1000 QS	1500 QS	2500 QS	2000 PS
Input Voltage	120Vvac			
Low Voltage Disconnect	85Vvac ± 4%			
Low Voltage Reconnect	95Vvac ± 4%			
High Voltage Disconnect	132Vvac ± 4%			
High Voltage Reconnect	136/253Vvac ± 4%			
Nominal Input Frequency	50Hz / 60Hz (Auto Detection)			
Transfer Switch Rating	30A			
Pass Through Without Battery	Yes			
Maximum Pass Through Overload	30A			

DC INPUT AMPERAGE

	DC Voltage (range)	DC Amps (max continuous)
TruePower Combi - Combination Charger / Inverter with Automatic Crossover		
(110 VAC 60 Hz.) 12 Volt QS Models		
01012	True Power Combi - 12V 40A/1000W Combination Charger/Inverter - 110Vvac 60hz	10.5 - 15Vdc Up to 100A
01512	True Power Combi - 12V 40A/1500W Combination Charger/Inverter - 110Vvac 60hz	10.5 - 15Vdc Up to 150A
02412	True Power Combi - 12V 40A/2500W Combination Charger/Inverter - 110Vvac 60hz	10.5 - 15Vdc Up to 250A
(110 VAC 60 Hz.) 24 Volt QS Models		
01524	True Power Combi - 24V 20A/1500W Combination Charger/Inverter - 110Vvac 60hz	21.5 - 29.5Vdc Up to 75A
02424	True Power Combi - 12V 40A/1500W Combination Charger/Inverter - 110Vvac 60hz	21.5 - 29.5Vdc Up to 125A
(230 VAC 50 Hz.) 12 Volt QS Models		
01513	True Power Combi - 12V 40A/1500W Combination Charger/Inverter - 230Vvac 50hz	10.5 - 15Vdc Up to 150A
02423	True Power Combi - 12V 50A/2500W Combination Charger/Inverter - 230Vvac 50hz	10.5 - 15Vdc Up to 250A
(230 VAC 50 Hz.) 24 Volt QS Models		
01525	True Power Combi - 24V 20A/1500W Combination Charger/Inverter - 230Vvac 50hz	21.5 - 29.5Vdc Up to 75A
02425	True Power Combi - 24V 25A/2500W Combination Charger/Inverter - 230Vvac 50hz	21.5 - 29.5Vdc Up to 125A

Pure Sine Wave Combination Charger / Inverter with Automatic Crossover

	DC Voltage (range)	DC Amps (max continuous)
(110 VAC 60 Hz.) PS Models		
02012	True Power Combi - 12V 70A/2000W Combination Charger/Inverter - 110Vvac 60hz	10.5 - 15Vdc Up to 200A
02024	True Power Combi - 24V 35A/2000W Combination Charger/Inverter - 230Vvac 50hz	21.5 - 29.5Vdc Up to 100A
(230 VAC 50 Hz.) PS Models		
02013	True Power Combi - 12V 70A/1500W Combination Charger/Inverter - 230Vvac 50hz	10.5 - 15Vdc Up to 200A
02025	True Power Combi - 24V 35A/2000W Combination Charger/Inverter - 230Vvac 50hz	21.5 - 29.5Vdc Up to 100A

Customer Service & Warranty

We are committed to customer satisfaction and value your business. If at any time during the warranty period you experience a problem with your new TruePower Combi simply call us at 1-800-824-0524 during standard business hours (8:30 AM – 5 PM Eastern Standard Time) for technical support.

TruePower Combi Two Year Limited Factory Warranty

Each TruePower Combi model is guaranteed against defects in material and workmanship to the original consumer in normal use for 2 years from the date of purchase. ProMariner will at its discretion repair or replace free of charge any defects in material or workmanship. The following conditions apply:

- Warranty is calculated from manufacture date if not registered within 30 days of purchase.
- Warranty void if unauthorized repairs attempted.
- Customer is responsible for returning the product to ProMariner. Inbound shipping costs must be paid by customer.
- This warranty does not cover blemishes due to normal wear and tear or damaged caused by accidents, abuse, alterations or misuse.
- Cosmetic repairs can be done at owner's request and expense.

Purchase or other acceptance of the product shall be on the condition and agreement that ProMariner SHALL NOT BE LIABLE FOR INCIDENTAL OR CONSEQUENTIAL DAMAGES OF ANY KIND. (Some states do not allow the exclusion or limitation of incidental or consequential damages, so the above limitations may not apply to you.) ProMariner neither assumes nor authorizes any person for any obligation or liability in connection with the sale of this product.

To make a claim under warranty, call 1-800-824-0524 or visit www.promariner.com identifying the product and giving its location. Follow the company's return instructions, which will then be provided by the company. ProMariner will make its best effort to repair or replace the product, if found defective within the terms of the warranty, within (30) days after return of the product to the company. ProMariner will ship the repaired or replaced product back to the purchaser.

This warranty gives you specific legal rights, and you may also have other rights, which vary from state to state. This warranty is in lieu of all others expressed or implied.

ProMariner
Factory Service Center & Technical Support
15 Dartmouth Drive, STE 101
Auburn, New Hampshire 03032

USA TOLL FREE: 1-800-824-0524
Tel: (603) 433-4440 / Fax: (603) 433-4442
Visit us on the web at: www.promariner.com